



LINOS Hand Fracture System

Lean. Complete. New!



reddot award 2016
winner



Our core competence is hand surgery, a field where we can offer you much more than just standard treatment solutions for, say, distal radius fractures. Many of our products are intended to help you to achieve outstanding results in difficult, non-everyday situations as well. Products such as our ulnar head prosthesis (UHP) or the Flower Plate for mediocarpal partial arthrodesis are excellent examples of this.

Our objective is to simplify hand surgery interventions through intelligent system solutions, helping you to achieve the best possible results in the interest of the patient. Working in close cooperation with well-known authors and their teams, we have translated new ideas into innovative products that are consistently being developed further in an ongoing process. The result is a wide range of high-quality systems that impress with their clever design along with easy and safe handling.

And what's more, we have never lost sight of the economic perspective and service needs of our customers.

We consider ourselves as a true partner – to be relied upon for routine tasks and special challenges alike.

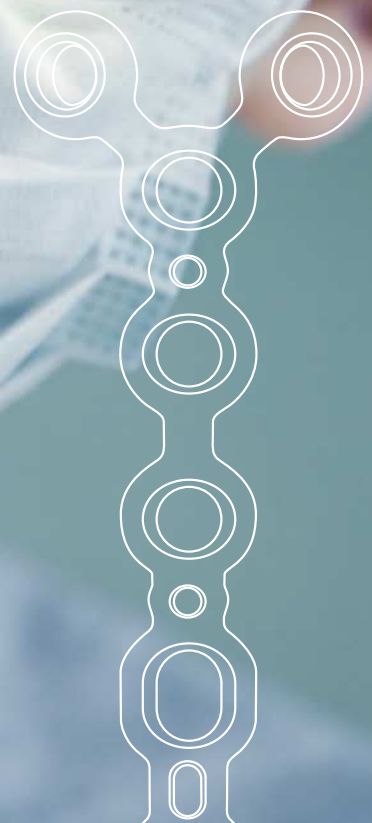

Table of Contents

	Pages
LINOS – Product Features	6-13
Indications and Surgical Techniques	14-37
<ul style="list-style-type: none"> ■ Transverse Fracture of the Metacarpal Bone Treatment with a 1.2-mm Grid Plate ■ Oblique Fracture of the Proximal Phalanx Treatment with a 0.8-mm T-Plate ■ Bony Extensor Tendon Avulsion of the Distal Phalanx Treatment with a Ø 1.2-mm smartDrive® Standard Screw 	16-23 24-31 32-37
Product Range	
<ul style="list-style-type: none"> ■ LINOS Implants ■ LINOS Instruments ■ LINOS Storage System ■ LINOS Storage System sterile 	38-47 48-55 56-63 64-65
Hand Surgery – Overview Implant Systems	66-67



LINOS *Hand Fracture System* – Lean. Complete. New!

Our main goals in developing the LINOS hand fracture system can be summarized as follows: building upon the success of the MOH system that has been on the market since 2004, learning from the feedback obtained from our customers in an effort to understand their needs even better, and adding new technical features for more efficient handling.

The LINOS hand fracture system provides you with a straightforward, yet nonetheless complete range of plates in two different profile thicknesses. They can be freely combined with the new smartDrive® standard and multidirectional locking screws with diameters of 1.5 mm, 2.0 mm and 2.3 mm. An add-on module for 1.2 mm diameter screw osteosynthesis is also available. The system is rounded off by just a handful of intuitive instruments.

Feature, Function and Benefit



The full range of plates in the LINOS system offers a comprehensive selection for all types of hand fractures seen in everyday surgical situations.

All the LINOS plates can be combined with both standard screws and with multidirectional locking screws – entirely according to individual requirements and the fracture being treated. The resulting high level of treatment stability enables early functional capacity for exercise.

The plates are available in two profile thicknesses and different anatomically contoured shapes and lengths.

To facilitate identification the two profiles have different color coding:

Green: Plates in profile thickness 0.8 mm

Dark gray: Plates in profile thickness 1.2 mm

The reduction of the plate portfolio to the essentials and the option of using standard and multidirectional locking screws in one and the same plate facilitates handling significantly and meets the current economic requirements of a state-of-the-art hand fracture system.

LINOS Plates

Features and functions

Benefits

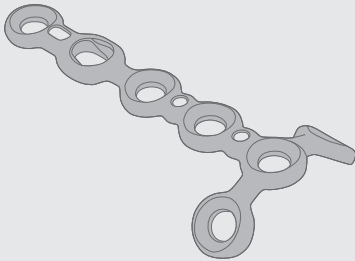

- Anatomical pre-shaped plate design
- Rounded, atraumatic plate contour

- Anatomical plate fit with minimal intra-operative adjustment
- High strength due to the reduced amount of bending
- Optimal embedding in soft tissue with a maximum of protection

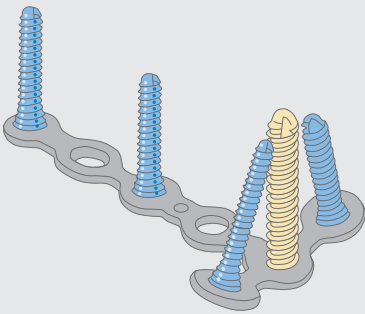

- Universal plate hole geometry

- All the plates can be combined both with smartDrive® standard screws and with multidirectional locking screws in diameters 1.5 mm, 2.0 mm and 2.3 mm
- Multiple options for an individual and best possible fracture treatment

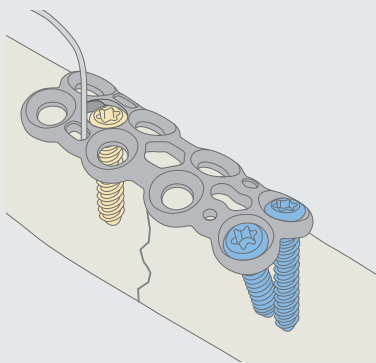

- Compression hole and elongated K-wire hole

- Secure closure of the fracture gap even when using grid plates

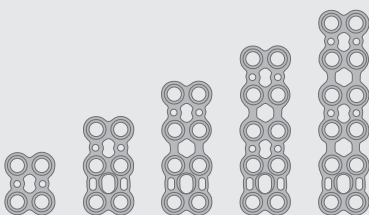

- Plates are available in different lengths

- Eliminates the need to shorten the plates
- No sharp edges and deburring

Feature, Function and Benefit



For screw osteosynthesis with small fragment fractures there are standard screws available with a diameter of 1.2 mm. If the fracture is being treated in combination with a plate, both standard screws and multidirectional locking screws can be used in diameters 1.5 mm, 2.0 mm and 2.3 mm. Free combinability ensures an optimal treatment option for every fracture. Clear identification of diameters is ensured with color-coded single clips.

Color code	Screw diameter
Blue:	1.2 mm
Green:	1.5 mm
Red:	2.0 mm
Black:	2.3 mm

Color-coded screws mean instant identification between standard and multidirectional locking screws, even when stored in the clip.

Color code	Screw	Diameter
Gold:	Standard screw	1.2 mm, 1.5 mm, 2.0 mm, 2.3 mm
Blue:	Locking screw	1.5 mm, 2.0 mm, 2.3 mm

smartDrive® Screws

Features and functions

Benefits

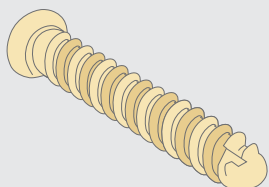

- Atraumatic screw head and tip

- Secure and soft-tissue-friendly bicortical anchorage in the bone

- Double, self-tapping thread

- Reduces application time by 50% and keeps the required effort to a minimum

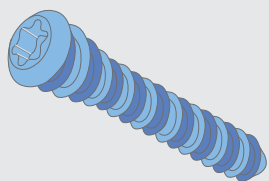

- Multidirectional locking screws in diameters 1.5 mm, 2.0 mm and 2.3 mm

- Secure, multidirectional locking of the screw in the plate (+/- 15°)
- Maximum range of angulation without causing soft tissue irritation

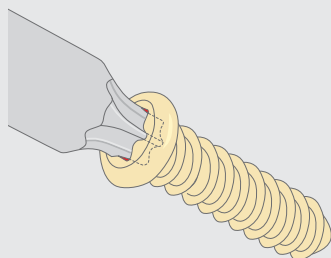

- T5 for screw diameter 1.2 mm and T6 for screw diameters 1.5 mm, 2.0 mm and 2.3 mm with self-retaining function

- Easy pick-up, insertion, tightening or removal of the screw
- Direct force transfer from the screwdriver blade to the screw
- Optimal synergy of handling and force transfer

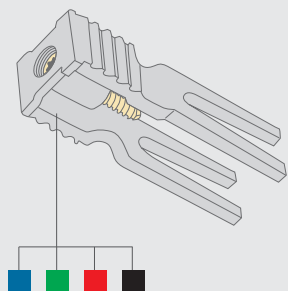

- Color-coded single clip

- Clear assignment of the appropriate screw diameter
- Direct, swift and application-oriented access
- 100% batch traceability
- Chargeable individually
- Simple record of all relevant implant data

Feature, Function and Benefit



KLS Martin has set itself the goal of optimizing the appropriate instrumentation with regard to easy and efficient handling.

This was why the designing of LINOS instruments focused not only on distinct color coding for easy identification but also on minimizing the total number of required instruments. For example, it is now possible to insert both standard screws and multi-directional locking screws in the three diameters, 1.5 mm, 2.0 mm and 2.3 mm, with one screwdriver.

Another concern was the development of reduction forceps especially designed to suit the anatomy of the hand. The result is the unique stepped design of the working ends. It allows easy, reliable reduction of the fracture while optimizing the preservation of soft tissue.

LINOS Instruments

Features and functions

Benefits

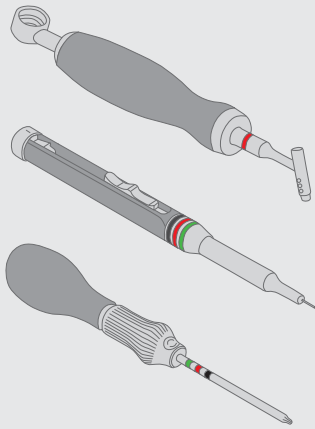

- Clear assignment and identification of instruments

- Color coding according to the appropriate screw diameter:
 - smartDrive® 1.2 mm (blue)
 - smartDrive® 1.5 mm (green)
 - smartDrive® 2.0 mm (red)
 - smartDrive® 2.3 mm (black)
- Differentiation between core hole drilling and gliding hole drilling for lag screw osteosynthesis:
 - Core hole (1 colored ring)
 - Gliding hole (2 colored rings)

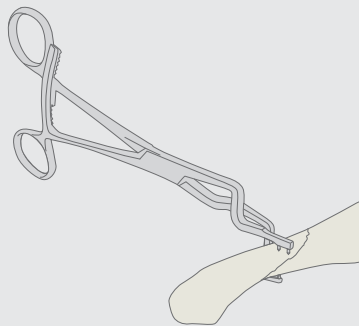

- Reduction forceps designed to suit the anatomy of the hand
- Unique stepped design of the working ends

- Easy, reliable reduction of the fracture
- Deflection possible in all directions
- Use in the region of the metacarpals possible

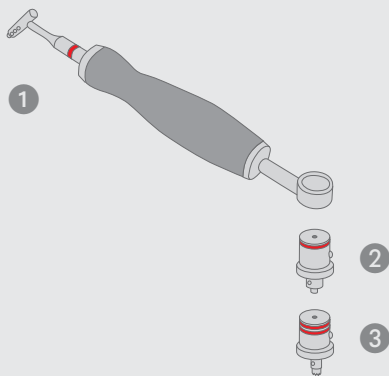

- Drill guide with two working ends

- Standard working end for core hole drilling ①
- Universal working end for clicking in the
 - Compression drill sleeve for eccentric drilling for the compression screw ②
 - Gliding hole drill sleeve for lag screw osteosynthesis ③



- Templates available for all plates

- Template reflects the plate 1-to-1
- Safe selection of the sterile-packed plate
- Positioning of the template on the bone using K-wire holes. When the template has been removed, the plate can be introduced as required using the placed K-wires.

Feature, Function
and Benefit



In designing the storage tray the focus was not only on easy handling but also on optimization of reprocessing capability, in order to meet the requirements of all those involved.

Apart from the option of conventional storage, the entire LINOS system is also available with sterile packed implants.

LINOS Storage

Features and functions

Benefits

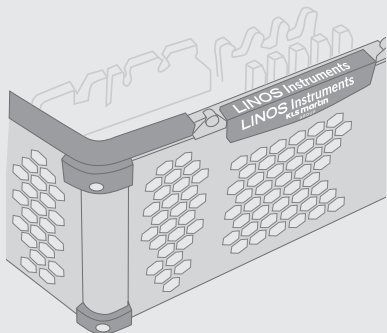

- Stainless steel storage tray in honeycomb design combined with high-performance plastic

- High stability, but low weight
- Good rinsing results due to large openings
- No water residues

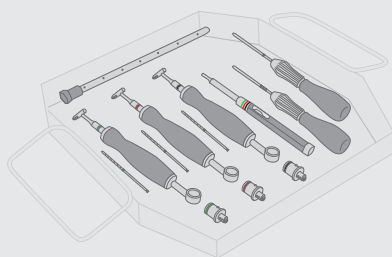

- The instruments are arranged according to the sequence of use in surgery

- Swift and intuitive supply of instruments during surgery
- User-friendly, efficient instrumentation

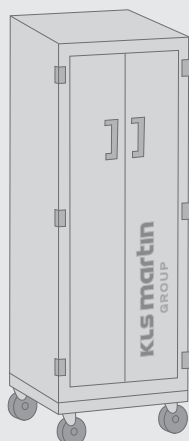

- Mobile sterile goods trolley
- Modular, labeled baskets and compartments

- Easy handling and supply of sterile implants in the operating room
- Optimal protection of sterile packages
- Swivel casters enable easy transport and transfer to and between operating rooms
- Excellently organized, structured stockkeeping
- Good overview and easy access to stored items
- Can be adapted to suit users' requirements at any time

Step by Step to Optimal Fixation

Indications

LINOS implants are used for the treatment and internal fixation of fractures of the distal, intermediate and proximal phalanges, and the metacarpals.

In addition, they can also be used for arthrodeses and reconstructive surgery in the hand region.



Avulsion fractures



Intra-articular fractures



Phalangeal fractures



Arthrodeses



Metacarpal fractures



Corrective procedures



Surgical Techniques

Transverse Fracture of the Metacarpal Bone

Treatment with a 1.2 mm grid plate

Pages 16-23

Prof. Dr. J. van Schoonhoven

Prof. Dr. C. Meyer

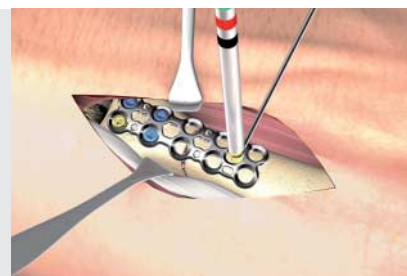

Oblique Fracture of the Proximal Phalanx

Treatment with a 0.8-mm T-plate

Pages 24-31

Prof. Dr. J. van Schoonhoven

Prof. Dr. C. Meyer

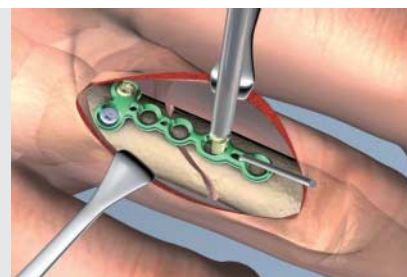

Bony Extensor Tendon Avulsion of the Distal Phalanx

Treatment with a Ø 1.2-mm smartDrive®

Standard Screw

Pages 32-37

Prof. Dr. J. van Schoonhoven

Prof. Dr. C. Meyer

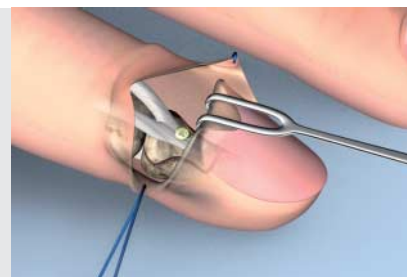



Preoperative planning

In addition to making standard exposures of the metacarpus with an A/P, strictly lateral and possibly also oblique beam, in the case of intra-articular fractures a high-resolution computed tomography scan is recommended for further clarification.

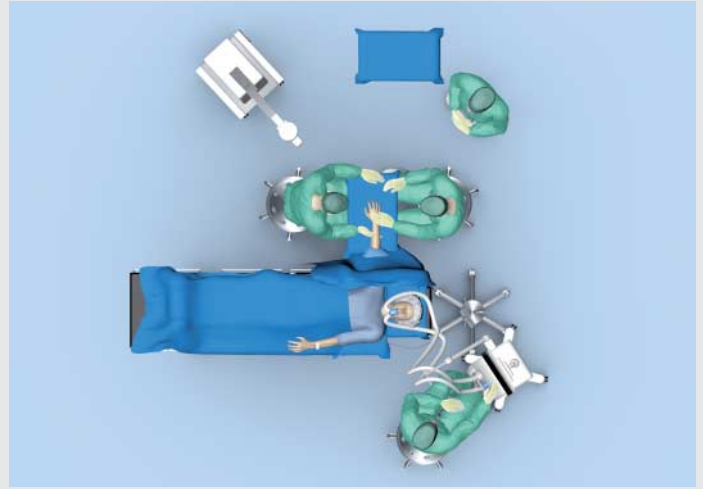

Patient positioning

The patient is placed in the supine position on the operating table. The hand to be operated on is placed in the pronation position of the lower arm on the hand side table.



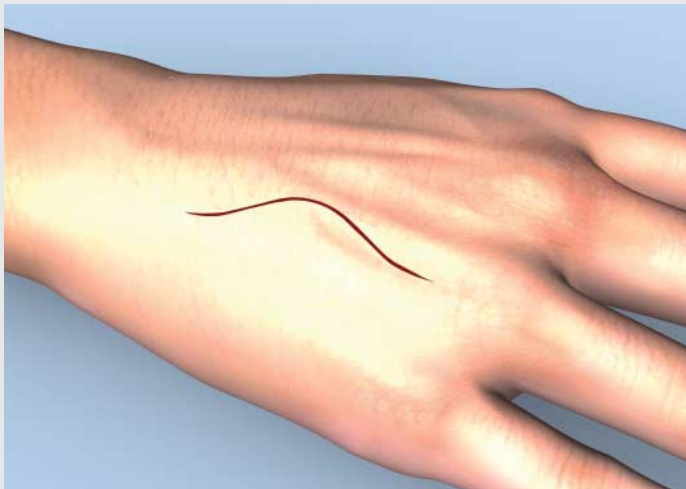

1. Dorsal approach

Opening is performed by making a dorsal, slightly curved incision above the relevant metacarpal bone.

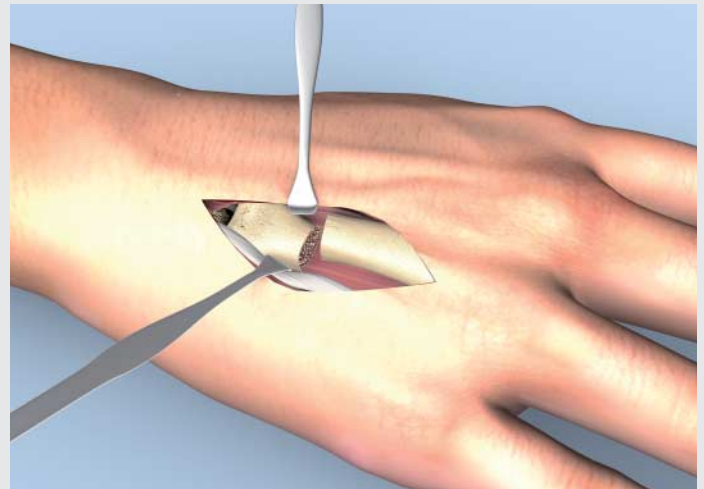

2. Exposure of the fracture

The skin incision is followed by blunt dissection of the subcutaneous tissue, protecting the dorsal veins of the hand and sensitive nerve branches.

The extensor tendons are mobilized and retracted together with the loosely connected soft tissue, preferably without transecting the tendinous junction.

In the next step the periosteum on the metacarpal is incised longitudinally and the dorsal interosseous muscles are partially released with the periosteum.

Note:

Complete release of the muscles and injury of the palmar structures must be prevented.

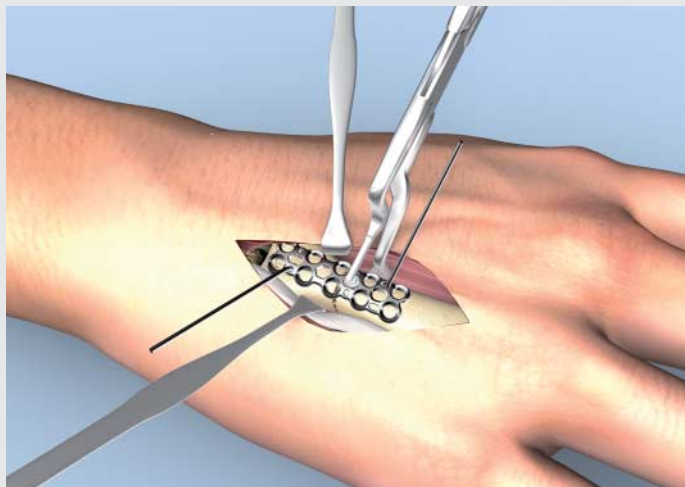
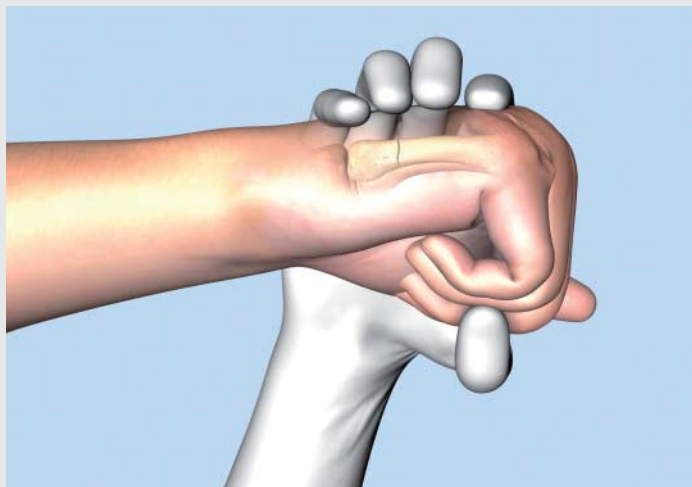

3. Reduction of the fracture

For manual reduction there are various techniques available.

It can be performed with maximum flexion of the MCP and PIP joints by applying slight thumb pressure to the middle phalanx and simultaneously applying counter pressure to the metacarpal with the other fingers.

When all the fingers close to the MCP joint are flexed, rotational alignment is achieved.

Optionally, if there is substantial instability, K-wires can be used for temporary fixation of the reduction.

In addition to manual reduction of the fracture by the surgeon, either the small Backhaus reduction forceps 23-721-09-07 integrated into the LINOS system can be used for spiral fractures or oblique fractures, or reduction forceps 26-975-06-07 with the stepped working end, specially developed for fractures in the hand region.

4. Selection and placement of the osteosynthesis plate

By way of example, treatment in the present indication is performed using a grid plate with a profile thickness of 1.2 mm. Since the grid plate has two rows, rotational stability can be increased, even if standard screws are used. However, the osteosynthesis plate is always selected according to the course of the fracture and the patient's anatomy.

If necessary, the osteosynthesis plate is adapted to the anatomical situation using the two plate bending forceps 26-975-05-07.

The plate can be temporarily fixated with plate holding forceps 26-975-04-07 and/or alternately with K-wires. Special K-wire slots are provided for this purpose. If fixation is performed with K-wires, it is advisable to first introduce a K-wire to the circular hole close to the joint and then introduce another K-wire to the elongated K-wire hole, at the side distant from the fracture.

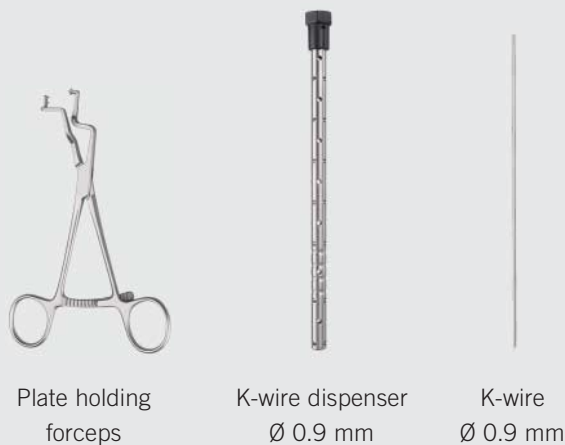

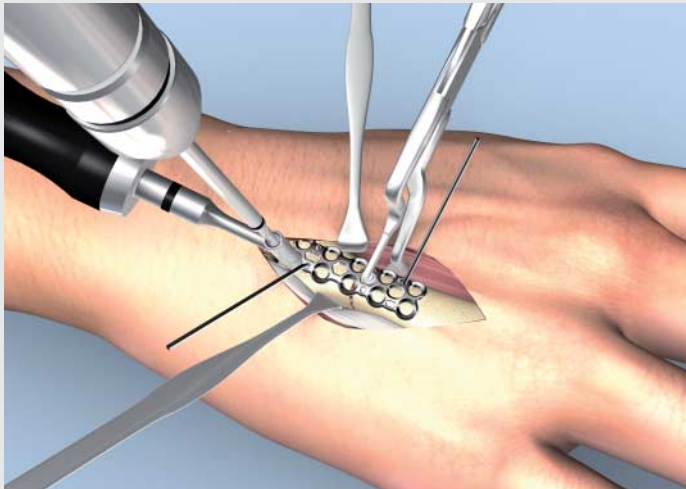









5. Drilling the first core hole

Depending on the course of the fracture, fracture compression via the plate can be indicated. If this is the case, the plate must first be fixated with screws on the side opposite the compression hole. To this end the core hole is first drilled with the aid of the drill guide and the appropriate core hole drill. The LINOS system makes it possible to use standard and multidirectional locking* smartDrive® screws with diameters 1.5 mm, 2.0 mm and 2.3 mm in all plate holes.

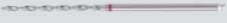
The table to the right shows which core hole bit has to be used in conjunction with which drill guide for the various screw diameters.

* In the compression hole only standard screws are used.

Ø Screw	Core hole drill	Drill guide
1.5 mm 	Ø 1.1 mm 26-153-11-07 26-153-11-71 	Ø 1.5 mm 26-975-75-07 
2.0 mm 	Ø 1.5 mm 26-153-16-07 26-153-16-71 	Ø 2.0 mm 26-975-80-07 
2.3 mm 	Ø 1.8 mm 26-153-18-07 26-153-18-71 	Ø 2.3 mm 26-975-85-07 



Core hole drill
Ø 1.8 mm



Drill guide
Ø 2.3 mm

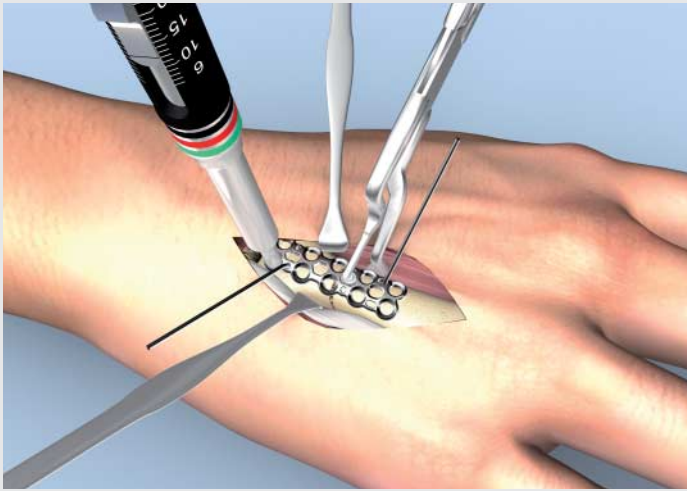

6. *Determination of screw length*

Correct screw length is determined with depth gauge 26-975-25-07, which can be used in all cases for screw diameters 1.5 mm, 2.0 mm and 2.3 mm.

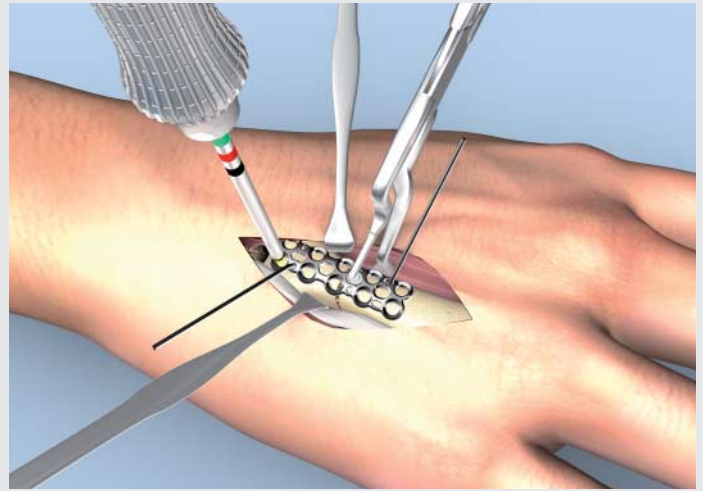

7. *Placement of the first screw*

After precise reduction of the fracture the plate is fixated with a smartDrive® standard screw. For this purpose the screw is picked up and driven in with the color-coded screwdriver 26-975-36-07, which is used for diameters 1.5 mm, 2.0 mm and 2.3 mm. Now more screws are placed by means of the technique described in steps 5-7. Optionally, multidirectional locking screws can be used to increase stability.

At this point, it is advisable to conduct a clinical assessment of correct rotation and make an X-ray to check the position of the implants.



Depth gauge (one-handed design)
1.5 mm, 2.0 mm and 2.3 mm



Screwdriver T6
short, rotatable

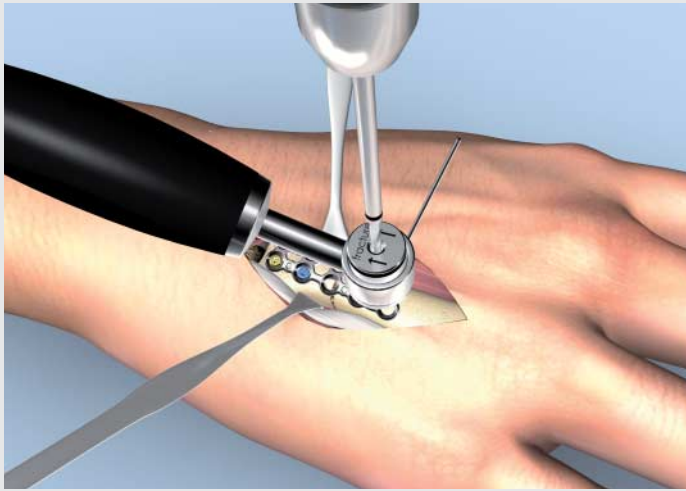

8. Placement of the compression screw

If compression plate osteosynthesis is planned, after successful introduction of the first screws the compression screw is now introduced to the compression hole in order to securely close the fracture gap. Standard screws with diameters 1.5 mm, 2.0 mm and 2.3 mm can be used. For this purpose the compression drill sleeve is clicked into the open working end of the drill guide from below. The arrows on the compression drill sleeve point toward the fracture gap when drilling. By analogy with the first screws, the core hole is drilled and the length of the screw is determined.

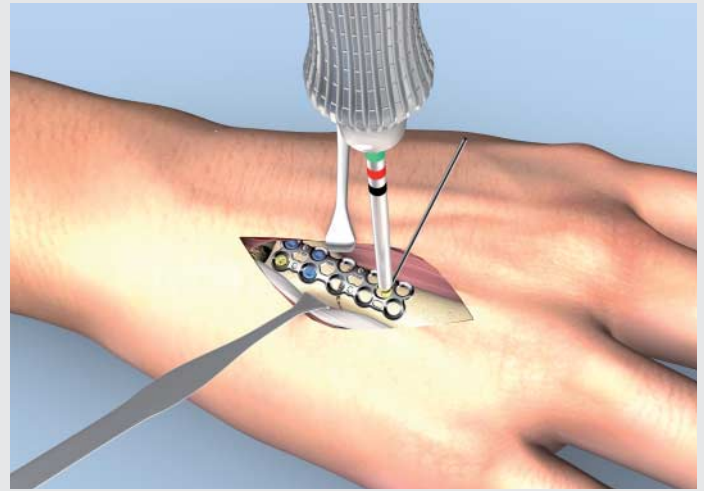

9. Closing the fracture gap

When it is being driven in, the smartDrive® standard screw glides over the sloping surface integrated into the compression hole, toward the fracture gap, and closes it.

To ensure that gliding takes place, the K-wire hole in the plate is also elongated so it allows the placed K-wire to also migrate when the fracture gap is being closed.

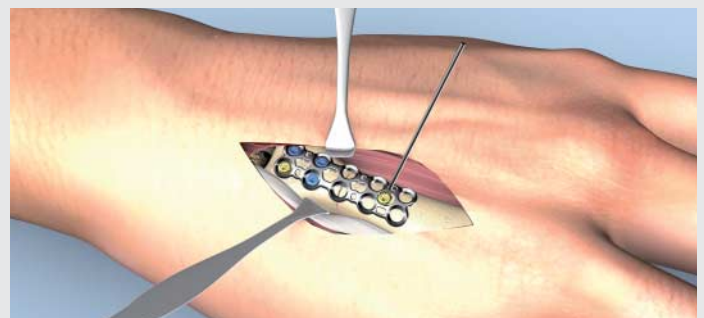

Core hole drill
Ø 1.8 mm



Drill guide
Ø 2.3 mm



Drill sleeve Ø 2.3 mm
compression



Screwdriver T6
short, rotatable

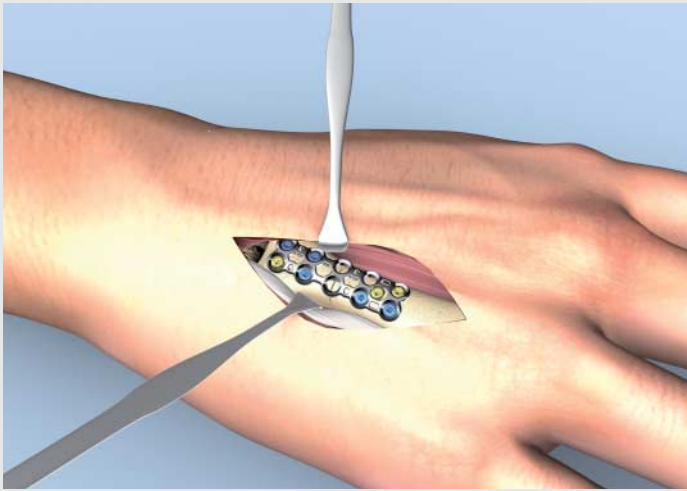

10. Placement of further screws

To achieve adequate early functional stability more distal plate holes are filled with screws.

The procedure for this is described in steps 5 to 7.

The number of screws and the selection of screw diameter and type depend on the specific anatomy of the patient and the required stability.

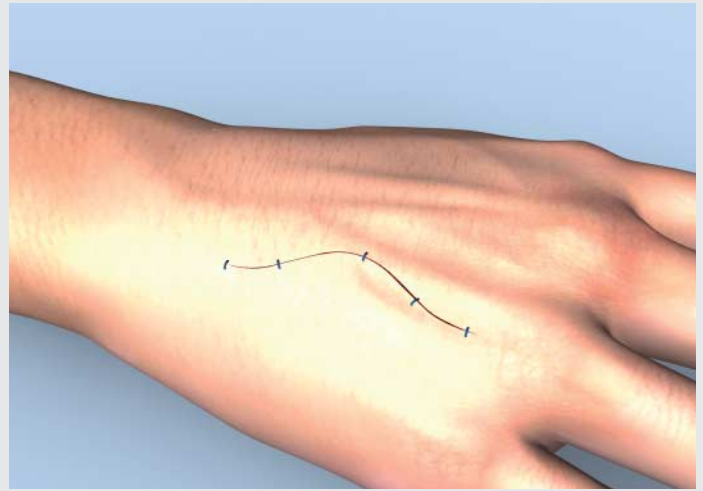

11. Wound closure

The flat implant design usually permits closure of the periosteum above the implants in order to prevent tendon adhesions.

That is followed by skin suture.



Screwdriver T6
short, rotatable



12. Postoperative treatment

After surgery, a detachable splint surrounding the metacarpus should be applied to protect the wound and the osteosynthesis, without including the fingers or inhibiting the metacarpophalangeal joints.

If patients with stable internal fixation are cooperative, the splint can be removed when swelling has subsided, otherwise 4-6 weeks after osteosynthesis.

At night the splint can be worn for a lengthy period if it helps to increase patient comfort.

Patients should begin exercises themselves directly after surgery in order to achieve free mobility of all the fingers, and especially the basal joints. If problems arise, hand therapy should be initiated at an early stage.

The stitches can be taken out 10 to 14 days after surgery.

A confirmation X-ray is made 6 weeks after internal fixation.



Preoperative planning

First of all, standard X-rays are taken in the A/P and lateral planes, with the hand in neutral position. In the case of intra-articular fractures a high-resolution computed tomography scan is recommended for further clarification.

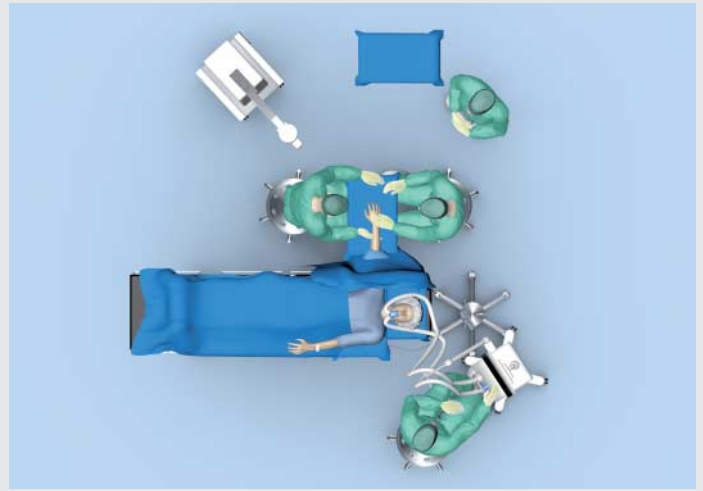

Patient positioning

The patient is placed in the supine position on the operating table. The hand to be operated on is placed in the pronation position of the lower arm on the extension table.



1. Approach

With simple types of fracture the lateral approach is recommended, with mobilization of the oblique portion, extensor aponeurosis, and lateral placement of the osteosynthesis implants. In the case of complex fractures or comminuted fracture zones the opening is made by a dorsal, slightly curved incision, starting at the level of the MCP joint, up to the PIP joint.

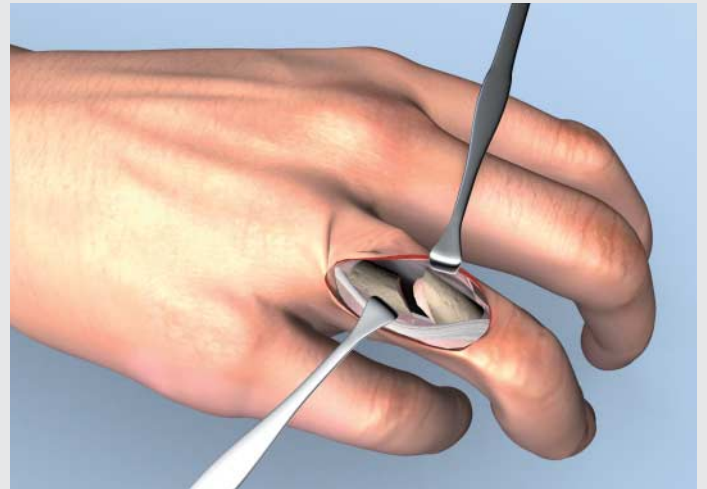

2. Exposure of the fracture

The skin incision is followed by blunt spreading of the subcutaneous tissue, with protection and local coagulation of the veins. When the extensor hood has been exposed, it is subjected to a median longitudinal incision. That is followed by subperiosteal exposure of the fractured proximal phalanx.

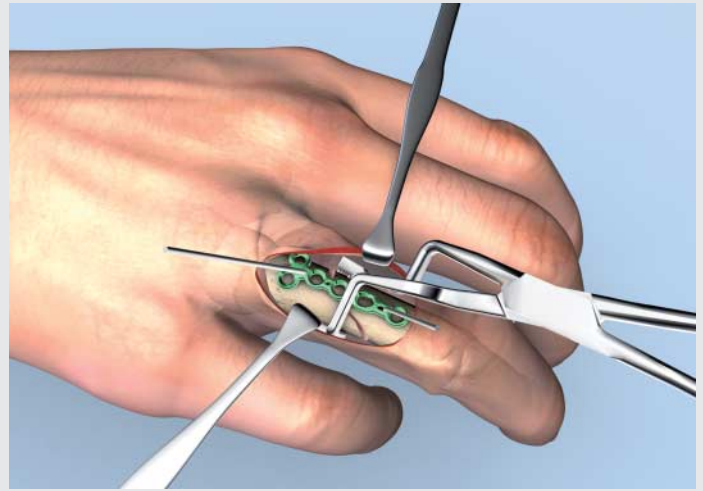
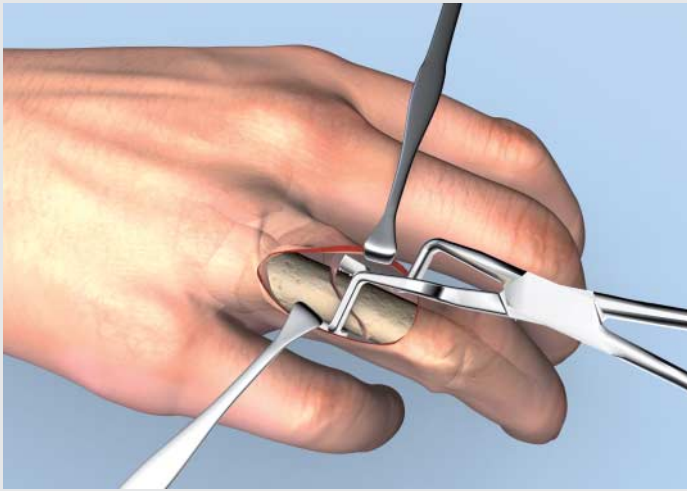

3. Reduction of the fracture

In addition to manual reduction of the fracture by the surgeon, either the small Backhaus reduction forceps 23-721-09-07 integrated into the LINOS system can be used, or reduction forceps 26-975-06-07 with the stepped working end, specially developed for hand fractures.

4. Selection and placement of the osteosynthesis plate

By way of example, treatment in the present indication is performed using a T-plate with a profile thickness of 0.8 mm. The osteosynthesis plate is always selected according to the course of the fracture and the patient's anatomy.

If necessary, the osteosynthesis plate is adapted to the anatomical situation using the two plate bending forceps 26-975-05-07.

The plate can be temporarily fixated with K-wires. Special K-wire holes are provided for this purpose. Alternatively, LINOS plate holding forceps 26-975-04-07 can also be used.



Reduction forceps
pointed/pointed

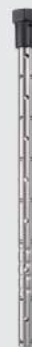

K-wire dispenser
Ø 0.9 mm

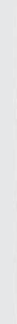

K-wire
Ø 0.9 mm

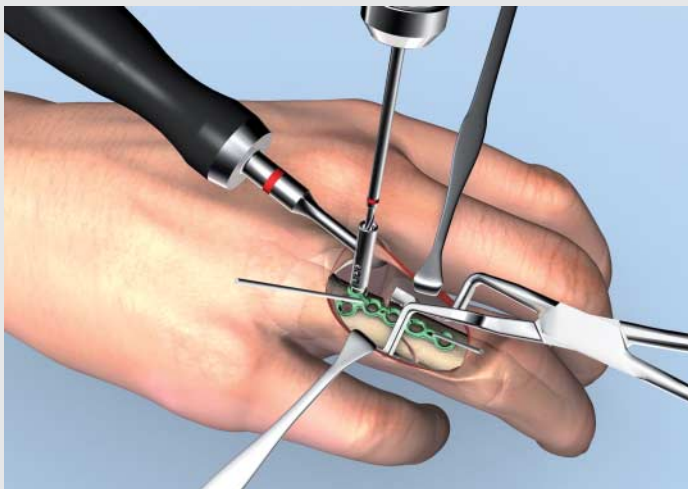









5. Drilling the first core hole

Depending on the course of the fracture, fracture compression via the plate can be indicated. In this case the plate must first be fixated on the side opposite the compression hole. To this end the core hole is drilled with the aid of the drill guide and the appropriate core hole drill. The LINOS system makes it possible to use standard and multidirectional locking smartDrive® screws with diameters 1.5 mm, 2.0 mm and 2.3 mm in all plate holes*.

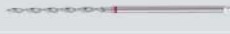
The table opposite shows which core hole drill has to be used in conjunction with which drill guide for the various screw diameters.

* In the compression hole only standard screws are used.

Ø Screw	Core hole drill	Drill guide
1.5 mm 	Ø 1.1 mm 26-153-11-07 26-153-11-71 	Ø 1.5 mm 26-975-75-07 
2.0 mm 	Ø 1.5 mm 26-153-16-07 26-153-16-71 	Ø 2.0 mm 26-975-80-07 
2.3 mm 	Ø 1.8 mm 26-153-18-07 26-153-18-71 	Ø 2.3 mm 26-975-85-07 



Core hole drill
Ø 1.5 mm



Drill guide
Ø 2.0 mm

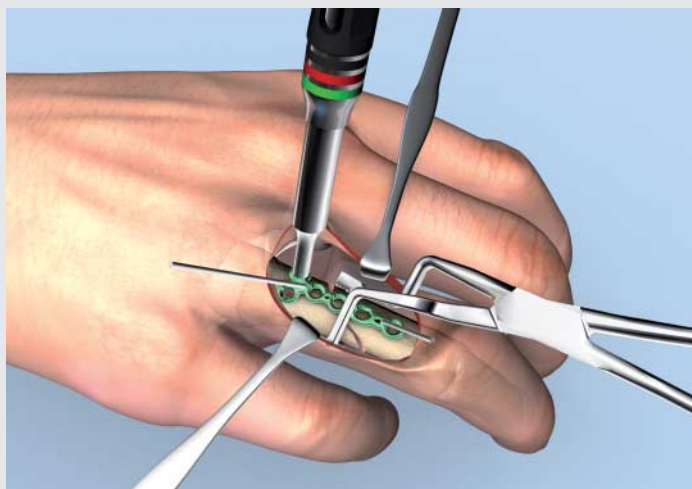

6. *Determination of screw length*

Correct screw length is determined with depth gauge 26-975-25-07, which can be used in all cases for screw diameters 1.5 mm, 2.0 mm and 2.3 mm.

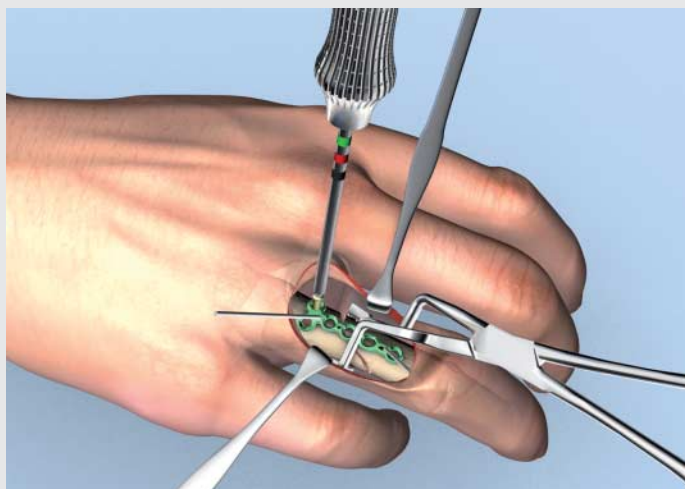

7. *Placement of the first screw*

The plate is first fixated with a smartDrive® standard screw. For this purpose the screw is picked up and inserted with the color-coded screwdriver 26-975-36-07, which is used for diameters 1.5 mm, 2.0 mm and 2.3 mm. Now the second screw is placed by means of the technique described in steps 5-7. Optionally, a multidirectional locking screw can be used to increase strength. At this point, it is advisable to conduct a clinical assessment of correct rotation and make an X-ray to check the position of the implants.

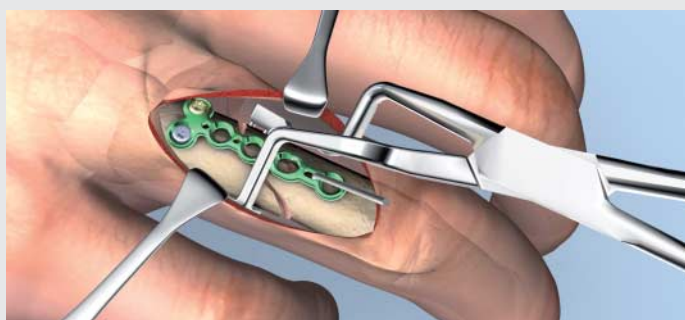
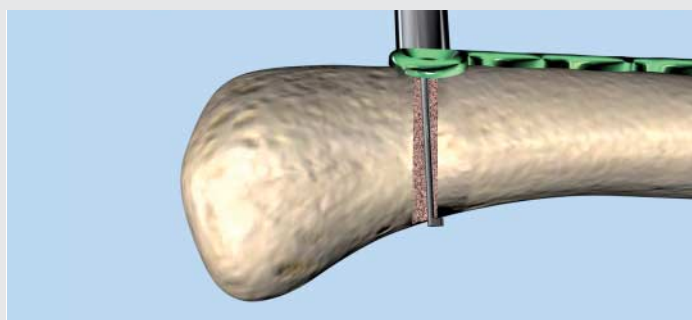

Depth gauge (one-handed design)
1.5 mm, 2.0 mm and 2.3 mm



T6 screwdriver
short, rotatable

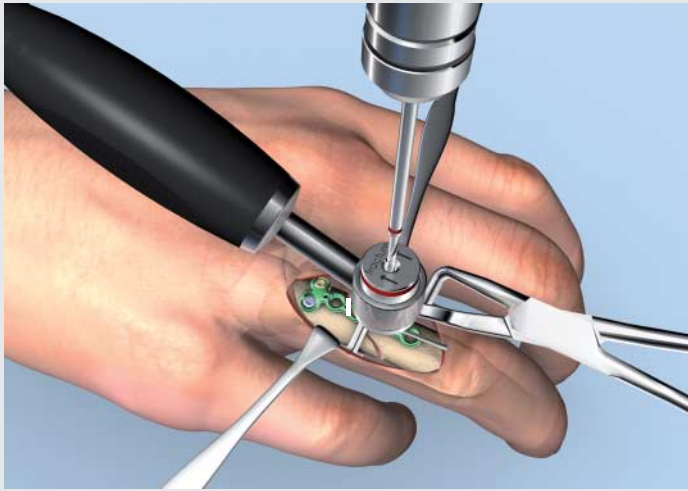

8. Placement of the compression screw

If compression plate osteosynthesis is planned, after successful implantation of the first screws the compression screw is now introduced to the compression hole in order to securely close the fracture gap. Standard screws with diameters 1.5 mm, 2.0 mm and 2.3 mm can be used. For this purpose the compression drill sleeve is clicked into the working end of the drill guide from below. The arrows on the compression drill sleeve point toward the fracture when drilling. By analogy with the first screws, the core hole is drilled and the length of the screw is determined.

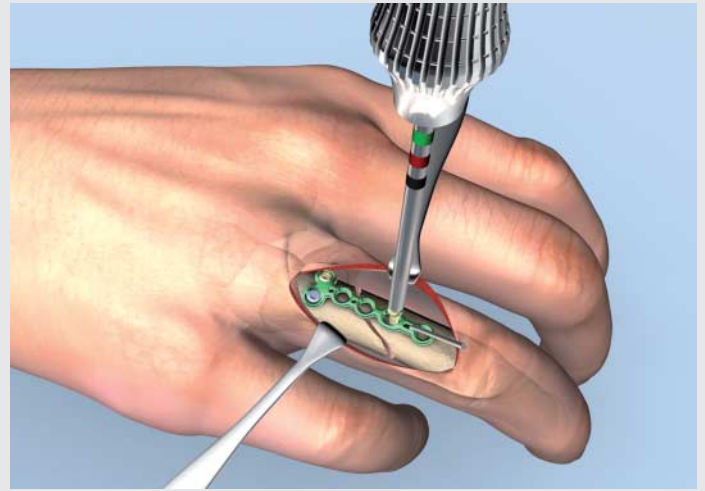

9. Closing the fracture gap

When it is being inserted, the smartDrive® standard screw glides over the sloping surface integrated into the compression hole, toward the fracture gap, and closes it.

To ensure that gliding takes place, the K-wire hole in the plate is also elongated so it allows the placed K-wire to also migrate when the fracture gap is being closed.

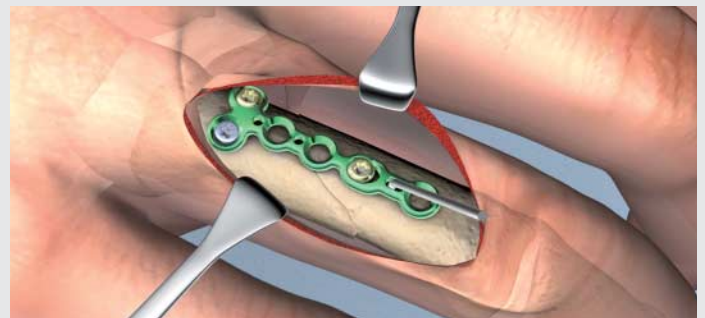

Core hole drill
Ø 1.5 mm



Drill guide
Ø 2.0 mm



Compression drill sleeve
Ø 2.0 mm



T6 screwdriver
short, rotatable

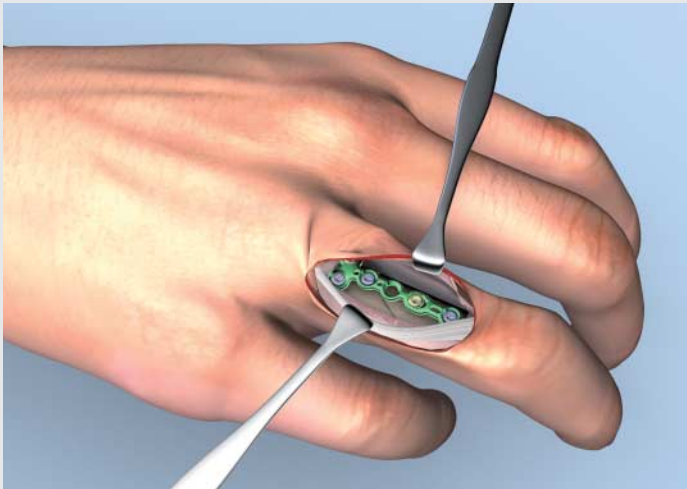

10. Placement of further screws

To achieve adequate early functional stability more plate holes are filled with screws. The procedure for this is described in steps 5 to 7.

The number of screws and the selection of screw diameter and type depend on the specific anatomy of the patient and the required stability.

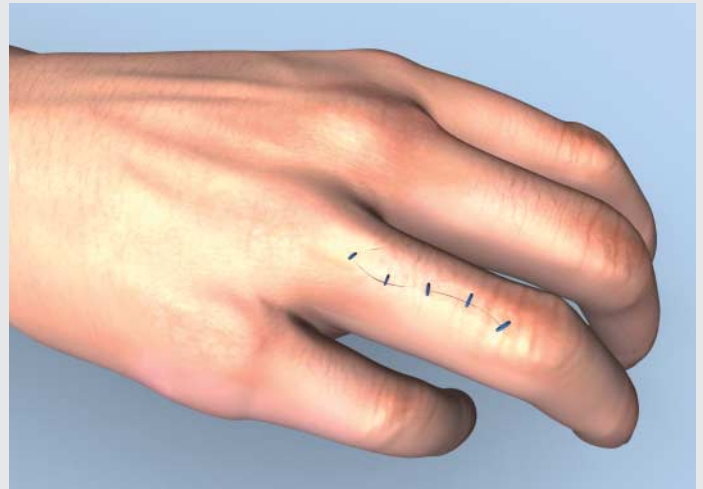

11. Wound closure

The flat implant design usually permits suture of the periosteum in order to prevent adhesions. That is followed by side-to-side suture of the extensor tendon and skin suture.



T6 screwdriver
short, rotatable



12. Postoperative treatment

Following surgery, immobilization for a few days may be advisable. Early functional after-treatment should commence as early as possible, adapted according to pain and swelling. The injured finger can be splinted to the adjacent finger in order to neutralize lateral forces acting on the finger.



Preoperative planning

The X-rays are taken in the A/P and lateral planes, with the finger in neutral, focusing on the distal interphalangeal joint.

The surgical indication for reduction and osteosynthesis is dislocation of the dorsal fragment and a fragment size that involves at least 1/3 of the joint surface, or palmar dislocation of the distal phalanx.

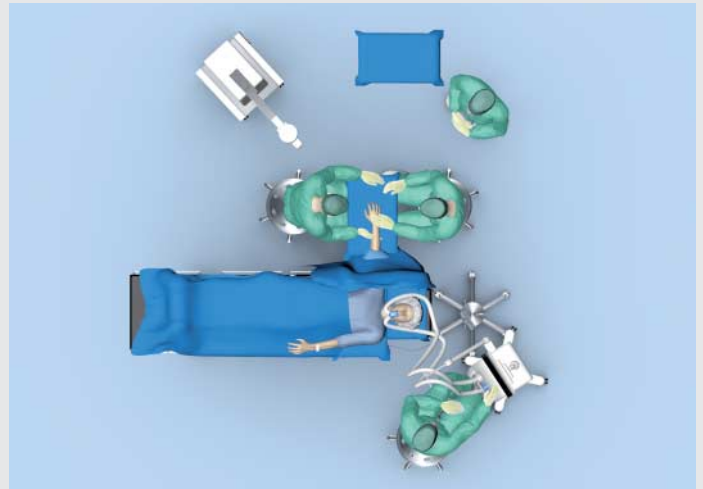

Patient positioning

The patient is placed in the supine position on the operating table. The hand to be operated on is placed in the pronation position of the lower arm on the extension table.



1. Dorsal approach

Opening is performed by making a Y-shaped skin incision over the distal interphalangeal joint on the extensor side, whereby the longitudinal portion is above the extensor tendon and terminates at the level of the distal interphalangeal joint. From here radial and ulnar incisions, each approximately 1 cm in length, are made on the distal palmar side of the nail fold. During incision and further preparation the nail matrix must be reliably protected.

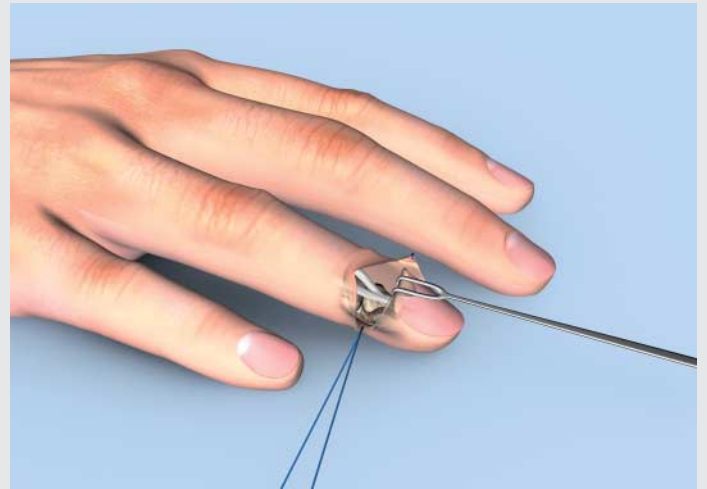

2. Exposure of the fracture

Skin incision is followed by exposure of the extensor aponeurosis and the joint fragment of the distal phalanx base. The still intact ulnar and radial tendon fibers and the matrix of the nail root may not be damaged. The fragment and fragment bed are cleaned to remove clots.



3. Reduction of the fracture

The DIP joint is extended. The fracture is reduced by applying light pressure to the palmar side of the distal phalanx and simultaneously applying counter pressure with the wide working end of drill guide 26-975-42-07 on the extensor side.

The reduction is maintained with the horizontal drill guide until final fixation of the fracture.



4. Drilling the first core hole

Following precise reduction of the fracture, drill sleeve 26-975-43-07 is inserted into the wide working end of the drill guide from above. It serves as a guide for the bit when drilling.

The core hole is drilled to a diameter of 1.0 mm using core hole drill 26-975-44-71. The core hole penetrates the cortical bone opposite.

After drilling, the drill sleeve is removed but the drill guide is left in place.



Drill guide
Ø 1.2 mm



Drill sleeve
Ø 1.2 mm



Core hole drill
Ø 1.0 mm

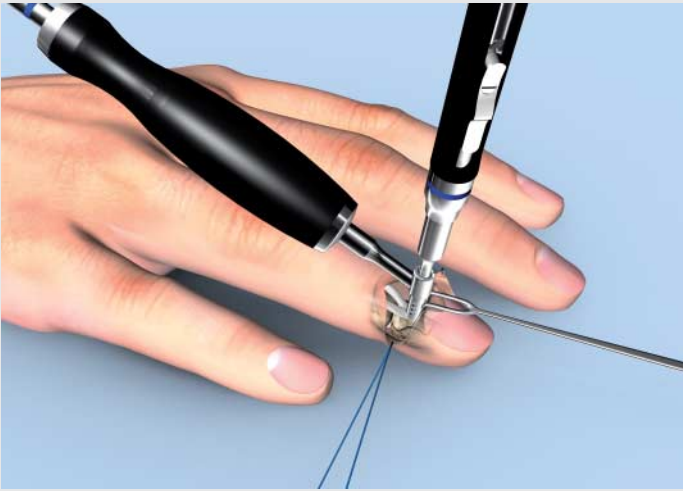

5. Determination of screw length

Correct screw length is determined with depth gauge 26-975-22-07 via the opening in the drill guide.

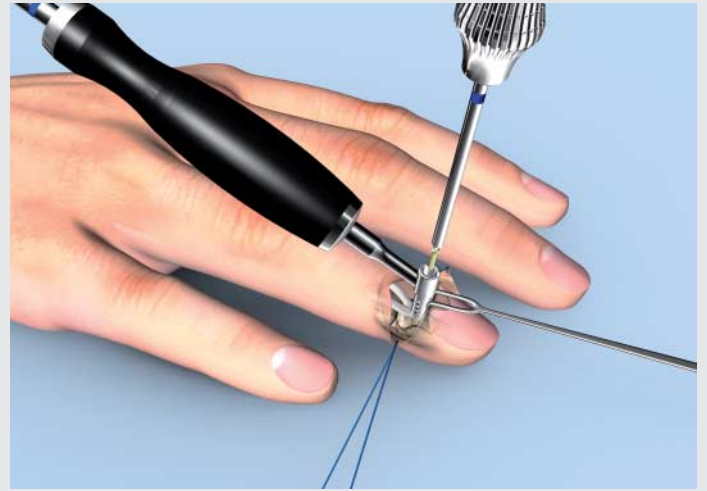

6. Placement of the screw

The fracture is fixated with a 1.2 mm diameter smartDrive® standard screw.

For this purpose the screw is picked up with color-coded screwdriver 26-975-33-07 and implanted via the opening in the drill guide. If screw length selected is ideal, the last thread turn grips in the opposite cortical bone while the atraumatic screw tip projects slightly.

An X-ray check is performed to verify the position of the screw.

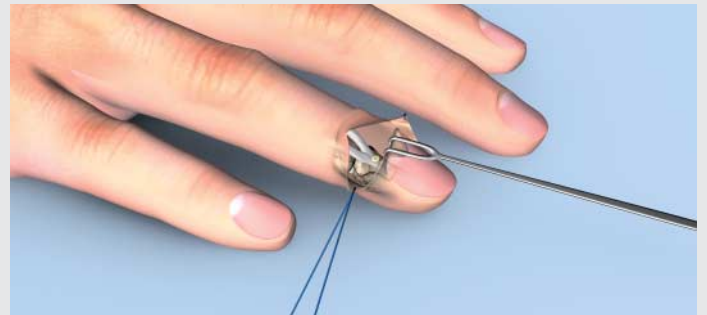
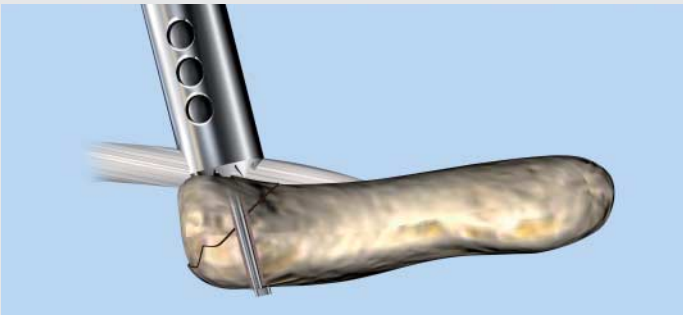

Depth gauge (one-handed design)
1.2 mm



T5 screwdriver
short, rotatable

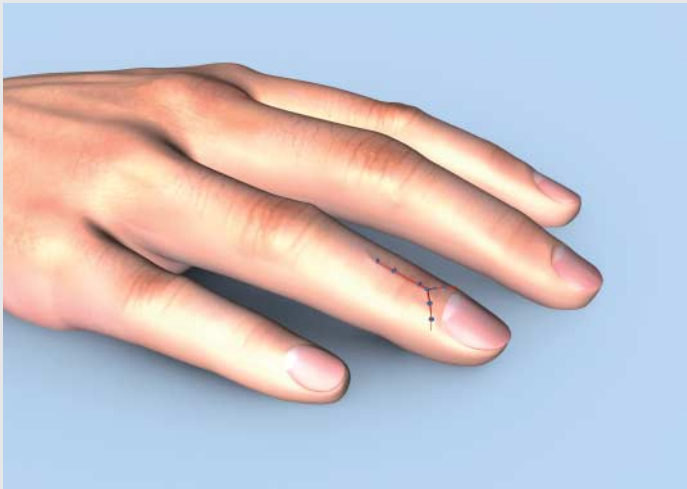

7. Wound closure

Skin suture is performed with non-absorbable suture material using the single button technique.



8. Postoperative treatment

After surgery, a lower-arm two-finger plaster splint is applied to the extensor side in the intrinsic-plus position, including the adjacent finger, or a plaster splint including the thumb.

The arm should be systematically supported in a raised position and regular wound checks are recommended. Removal of the suture, usually accompanied by removal of the plaster cast, is performed about two weeks after surgery. Further immobilization of the joint that has been operated on can be achieved using a Stack splint if necessary.

Physiotherapeutic exercise treatment (active and passive exercises) can commence.

Implants **LINOS**

Plates in Profile Thickness 0.8 mm

Straight plate
4-hole
Length 19.5 mm

Straight plate
5-hole
Length 26.5 mm

Straight plate
6-hole
Length 31.5 mm

Z-plate
9-hole
Length 24.5 mm

Z-plate
13-hole
Length 34.5 mm



26-108-12-09
26-108-12-71
STERILE | R



26-108-13-09
26-108-13-71
STERILE | R



26-108-14-09
26-108-14-71
STERILE | R



26-108-20-09
26-108-20-71
STERILE | R



26-108-21-09
26-108-21-71
STERILE | R



Templates

for the safe selection of the sterile packed plate

26-208-12-09
Template



26-208-13-09
Template



26-208-14-09
Template



26-208-20-09
Template



26-208-21-09
Template





Explanation of icons

- Titanium
- Packaging unit
- Multidirectional locking screw hole
- Plate profile

STERILE | R Sterile packaged implants

Grid plate
2/2-hole
Length 10.5 mm

Grid plate
2/3-hole
Length 15.5 mm

Grid plate
2/4-hole
Length 20.5 mm

Grid plate
2/5-hole
Length 25.5 mm

Grid plate
2/6-hole
Length 30.5 mm

Correction plate
3/3-hole
Length 26.5 mm



1/1
26-108-15-09
26-108-15-71
STERILE | R

= 0.8 mm

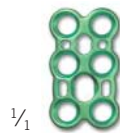

1/1
26-108-16-09
26-108-16-71
STERILE | R

= 0.8 mm



1/1
26-108-17-09
26-108-17-71
STERILE | R

= 0.8 mm



1/1
26-108-18-09
26-108-18-71
STERILE | R

= 0.8 mm



1/1
26-108-19-09
26-108-19-71
STERILE | R

= 0.8 mm



1/1
26-108-22-09
26-108-22-71
STERILE | R

= 0.8 mm

Templates

for the safe selection of the sterile packed plate

26-208-15-09
Template

26-208-16-09
Template

26-208-17-09
Template

26-208-18-09
Template

26-208-19-09
Template

26-208-22-09
Template

Implants **LINOS**

Plates in Profile Thickness 0.8 mm

T-plate
2/3-hole
Length 19.5 mm

T-plate
2/4-hole
Length 26.5 mm

T-plate
2/5-hole
Length 31.5 mm

T-plate
3/3-hole
Length 19.5 mm

T-plate
3/4-hole
Length 26.5 mm

T-plate
3/5-hole
Length 31.5 mm



1/4

26-108-06-09

26-108-06-71

STERILE | R



= 0.8 mm



1/4

26-108-07-09

26-108-07-71

STERILE | R



= 0.8 mm



1/4

26-108-08-09

26-108-08-71

STERILE | R



= 0.8 mm



1/4

26-108-09-09

26-108-09-71

STERILE | R



= 0.8 mm



1/4

26-108-10-09

26-108-10-71

STERILE | R



= 0.8 mm



1/4

26-108-11-09

26-108-11-71

STERILE | R



= 0.8 mm

Templates

for the safe selection of the sterile packed plate

26-208-06-09

Template



26-208-07-09

Template



26-208-08-09

Template



26-208-09-09

Template



26-208-10-09

Template



26-208-11-09

Template



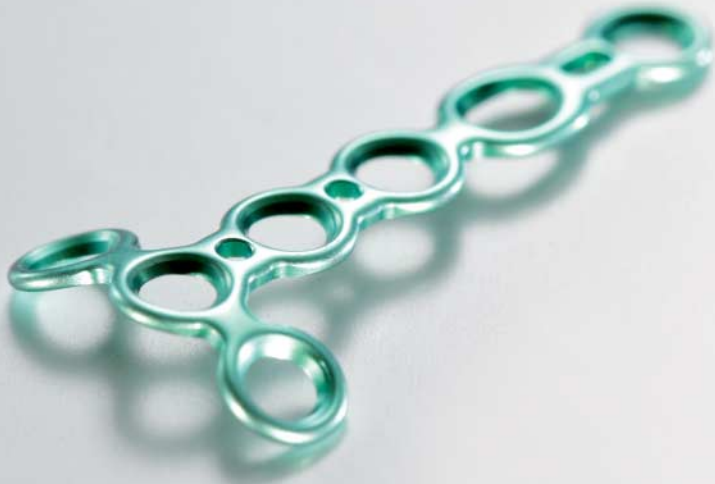

Explanation of icons

- Titanium
- Packaging unit
- Multidirectional locking screw hole
- Plate profile

STERILE | R Sterile packaged implants

Y-plate

2/3-hole
Length 18 mm

Y-plate

2/4-hole
Length 25 mm

Y-plate

2/5-hole
Length 30 mm

L-plate

6-hole, right
Length 26.5 mm

L-plate

6-hole, left
Length 26.5 mm

Washer

Ø 4.5 mm

$\frac{1}{2}$

26-108-03-09
26-108-03-71
STERILE | R

= 0.8 mm

$\frac{1}{2}$

26-108-04-09
26-108-04-71
STERILE | R

= 0.8 mm

$\frac{1}{2}$

26-108-05-09
26-108-05-71
STERILE | R

= 0.8 mm

$\frac{1}{2}$

26-108-01-09
26-108-01-71
STERILE | R

= 0.8 mm

$\frac{1}{2}$

26-108-02-09
26-108-02-71
STERILE | R

= 0.8 mm

$\frac{1}{2}$

26-108-23-71
STERILE | R

= 0.8 mm

Templates

for the safe selection of the sterile packed plate

26-208-03-09
Template

26-208-04-09
Template

26-208-05-09
Template

26-208-01-09
Template

26-208-02-09
Template

Implants LINOS

Plates in Profile Thickness 1.2 mm

Straight plate
4-hole
Length 24.5 mm

Straight plate
5-hole
Length 32 mm

Straight plate
6-hole
Length 38.5 mm

Straight plate
7-hole
Length 45 mm

Z-plate
9-hole
Length 31 mm

Z-plate
13-hole
Length 44 mm

Correction plate
3/3-hole
Length 31 mm



26-112-12-09

26-112-12-71

STERILE | R



26-112-13-09

26-112-13-71

STERILE | R



26-112-14-09

26-112-14-71

STERILE | R



26-112-27-09

26-112-27-71

STERILE | R



26-112-20-09

26-112-20-71

STERILE | R



26-112-21-09

26-112-21-71

STERILE | R

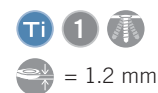

26-112-22-09

26-112-22-71

STERILE | R



Templates

for the safe selection of the sterile packed plate

26-212-12-09

Template



26-212-13-09

Template



26-212-14-09

Template



26-212-27-09

Template



26-212-20-09

Template



26-212-21-09

Template



26-212-22-09

Template





Explanation of icons

- Titanium
- Packaging unit
- Multidirectional locking screw hole
- Plate profile

STERILE | R Sterile packaged implants

Grid plate
2/2-hole
Length 11.5 mm

Grid plate
2/3-hole
Length 18 mm

Grid plate
2/4-hole
Length 24.5 mm

Grid plate
2/5-hole
Length 31 mm

Grid plate
2/6-hole
Length 37.5 mm

Grid plate
2/7-hole
Length 44 mm

Grid plate
2/8-hole
Length 50.5 mm

26-112-15-09	26-112-16-09	26-112-17-09	26-112-18-09	26-112-19-09	26-112-30-71	26-112-31-71
26-112-15-71	26-112-16-71	26-112-17-71	26-112-18-71	26-112-19-71	26-112-30-71	26-112-31-71
STERILE R	STERILE R	STERILE R	STERILE R	STERILE R	STERILE R	STERILE R
= 1.2 mm	= 1.2 mm	= 1.2 mm	= 1.2 mm	= 1.2 mm	= 1.2 mm	= 1.2 mm

Templates



















for the safe selection of the sterile packed plate

26-212-15-09	26-212-16-09	26-212-17-09	26-212-18-09	26-212-19-09	26-212-30-09	26-212-31-09
Template	Template	Template	Template	Template	Template	Template

Implants LINOS





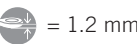
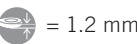
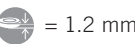
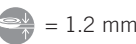
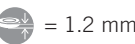
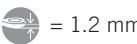
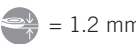
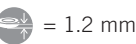
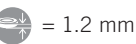



Plates in Profile Thickness 1.2 mm

<i>T-plate</i> 2/3-hole Length 24.5 mm	<i>T-plate</i> 2/4-hole Length 32 mm	<i>T-plate</i> 2/5-hole Length 38.5 mm	<i>T-plate</i> 2/6-hole Length 45 mm	<i>T-plate</i> 2/7-hole Length 51.5 mm	<i>T-plate</i> 3/3-hole Length 24.5 mm	<i>T-plate</i> 3/4-hole Length 32 mm	<i>T-plate</i> 3/5-hole Length 38.5 mm	<i>T-plate</i> 3/6-hole Length 45 mm
----------------------------------------------	--------------------------------------------	----------------------------------------------	--------------------------------------------	----------------------------------------------	----------------------------------------------	--------------------------------------------	----------------------------------------------	--------------------------------------------

								
1/1	1/1	1/1	1/1	1/1	1/1	1/1	1/1	1/1
26-112-06-09	26-112-07-09	26-112-08-09	26-112-25-09	26-112-29-09	26-112-09-09	26-112-10-09	26-112-11-09	26-112-26-09
26-112-06-71	26-112-07-71	26-112-08-71	26-112-25-71	26-112-29-71	26-112-09-71	26-112-10-71	26-112-11-71	26-112-26-71
STERILE R	STERILE R	STERILE R	STERILE R	STERILE R	STERILE R	STERILE R	STERILE R	STERILE R
								
 = 1.2 mm	 = 1.2 mm	 = 1.2 mm	 = 1.2 mm	 = 1.2 mm	 = 1.2 mm	 = 1.2 mm	 = 1.2 mm	 = 1.2 mm

Templates

for the safe selection of the sterile packed plate

26-212-06-09	26-212-07-09	26-212-08-09	26-212-25-09	26-212-29-09	26-212-09-09	26-212-10-09	26-212-11-09	26-212-26-09
Template	Template	Template	Template	Template	Template	Template	Template	Template
								



Explanation of icons

- Titanium
- Packaging unit
- Multidirectional locking screw hole
- Plate profile

STERILE | R Sterile packaged implants

<i>Y-plate</i> 2/3-hole Length 22.6 mm	<i>Y-plate</i> 2/4-hole Length 30.1 mm	<i>Y-plate</i> 2/5-hole Length 36.5 mm	<i>Y-plate</i> 2/6-hole Length 43 mm	<i>Y-plate</i> 2/7-hole Length 49.5 mm	<i>L-plate</i> 7-hole, right Length 38.5 mm	<i>L-plate</i> 7-hole, left Length 38.5 mm	<i>Washer</i> Ø 5.0 mm
----------------------------------------------	----------------------------------------------	----------------------------------------------	--------------------------------------------	----------------------------------------------	---------------------------------------------------	--------------------------------------------------	---------------------------

1/1	1/1	1/1	1/1	1/1	1/1	1/1	1/1
26-112-03-09	26-112-04-09	26-112-05-09	26-112-24-09	26-112-28-71	26-112-01-09	26-112-02-09	26-112-23-71
STERILE R	STERILE R	STERILE R	STERILE R	STERILE R	STERILE R	STERILE R	STERILE R
= 1.2 mm	= 1.2 mm	= 1.2 mm	= 1.2 mm	= 1.2 mm	= 1.2 mm	= 1.2 mm	= 1.2 mm

Templates

for the safe selection of the sterile packed plate

26-212-03-09	26-212-04-09	26-212-05-09	26-212-24-09	26-212-28-09	26-212-01-09	26-212-02-09
Template	Template	Template	Template	Template	Template	Template

Implants **LINOS** smartDrive® Screws

∅ 1.2 mm

Standard screw



1/16

Length	STERILE R
5 mm	26-012-05-71
6 mm	26-012-06-71
7 mm	26-012-07-71
8 mm	26-012-08-71
9 mm	26-012-09-71
10 mm	26-012-10-71
11 mm	26-012-11-71
12 mm	26-012-12-71
13 mm	26-012-13-71
14 mm	26-012-14-71

∅ 1.5 mm

Standard screw



1/16

Length	Art. No.	STERILE R	Art. No.	STERILE R
6 mm	26-015-06-91	26-015-06-71	26-014-06-91	26-014-06-71
7 mm	26-015-07-91	26-015-07-71	26-014-07-91	26-014-07-71
8 mm	26-015-08-91	26-015-08-71	26-014-08-91	26-014-08-71
9 mm	26-015-09-91	26-015-09-71	26-014-09-91	26-014-09-71
10 mm	26-015-10-91	26-015-10-71	26-014-10-91	26-014-10-71
11 mm	26-015-11-91	26-015-11-71	26-014-11-91	26-014-11-71
12 mm	26-015-12-91	26-015-12-71	26-014-12-91	26-014-12-71
13 mm	26-015-13-91	26-015-13-71	26-014-13-91	26-014-13-71
14 mm	26-015-14-91	26-015-14-71	26-014-14-91	26-014-14-71
15 mm	26-015-15-91	26-015-15-71	26-014-15-91	26-014-15-71
16 mm	26-015-16-91	26-015-16-71	26-014-16-91	26-014-16-71
17 mm	26-015-17-91	26-015-17-71	26-014-17-91	26-014-17-71
18 mm	26-015-18-91	26-015-18-71	26-014-18-91	26-014-18-71
19 mm	26-015-19-91	26-015-19-71	26-014-19-91	26-014-19-71
20 mm	26-015-20-91	26-015-20-71	26-014-20-91	26-014-20-71

Multidirectional locking screw



1/16



Explanation of icons

- Screw diameter 1.2 mm
- Screw diameter 1.5 mm
- Screw diameter 2.0 mm
- Screw diameter 2.3 mm
- Titanium
- T-Drive
- Packaging unit

STERILE | R Sterile packaged implants

Ø 2.0 mm

Standard screw

Multidirectional locking screw



1/1



1/1



Length	Art. No.	STERILE R	Art. No.	STERILE R
6 mm	26-020-06-91	26-020-06-71	26-019-06-91	26-019-06-71
7 mm	26-020-07-91	26-020-07-71	26-019-07-91	26-019-07-71
8 mm	26-020-08-91	26-020-08-71	26-019-08-91	26-019-08-71
9 mm	26-020-09-91	26-020-09-71	26-019-09-91	26-019-09-71
10 mm	26-020-10-91	26-020-10-71	26-019-10-91	26-019-10-71
11 mm	26-020-11-91	26-020-11-71	26-019-11-91	26-019-11-71
12 mm	26-020-12-91	26-020-12-71	26-019-12-91	26-019-12-71
13 mm	26-020-13-91	26-020-13-71	26-019-13-91	26-019-13-71
14 mm	26-020-14-91	26-020-14-71	26-019-14-91	26-019-14-71
15 mm	26-020-15-91	26-020-15-71	26-019-15-91	26-019-15-71
16 mm	26-020-16-91	26-020-16-71	26-019-16-91	26-019-16-71
17 mm	26-020-17-91	26-020-17-71	26-019-17-91	26-019-17-71
18 mm	26-020-18-91	26-020-18-71	26-019-18-91	26-019-18-71
19 mm	26-020-19-91	26-020-19-71	26-019-19-91	26-019-19-71
20 mm	26-020-20-91	26-020-20-71	26-019-20-91	26-019-20-71
22 mm	-	26-020-22-71	-	26-019-22-71
24 mm	-	26-020-24-71	-	26-019-24-71
26 mm	-	26-020-26-71	-	26-019-26-71
28 mm	-	26-020-28-71	-	26-019-28-71
30 mm	-	26-020-30-71	-	26-019-30-71

Ø 2.3 mm

Standard screw

Multidirectional locking screw



1/1



1/1



Length	Art. No.	STERILE R	Art. No.	STERILE R
6 mm	26-023-06-91	26-023-06-71	26-022-06-91	26-022-06-71
7 mm	26-023-07-91	26-023-07-71	26-022-07-91	26-022-07-71
8 mm	26-023-08-91	26-023-08-71	26-022-08-91	26-022-08-71
9 mm	26-023-09-91	26-023-09-71	26-022-09-91	26-022-09-71
10 mm	26-023-10-91	26-023-10-71	26-022-10-91	26-022-10-71
11 mm	26-023-11-91	26-023-11-71	26-022-11-91	26-022-11-71
12 mm	26-023-12-91	26-023-12-71	26-022-12-91	26-022-12-71
13 mm	26-023-13-91	26-023-13-71	26-022-13-91	26-022-13-71
14 mm	26-023-14-91	26-023-14-71	26-022-14-91	26-022-14-71
15 mm	26-023-15-91	26-023-15-71	26-022-15-91	26-022-15-71
16 mm	26-023-16-91	26-023-16-71	26-022-16-91	26-022-16-71
17 mm	26-023-17-91	26-023-17-71	26-022-17-91	26-022-17-71
18 mm	26-023-18-91	26-023-18-71	26-022-18-91	26-022-18-71
19 mm	26-023-19-91	26-023-19-71	26-022-19-91	26-022-19-71
20 mm	26-023-20-91	26-023-20-71	26-022-20-91	26-022-20-71
22 mm	-	26-023-22-71	-	26-022-22-71
24 mm	-	26-023-24-71	-	26-022-24-71
26 mm	-	26-023-26-71	-	26-022-26-71
28 mm	-	26-023-28-71	-	26-022-28-71
30 mm	-	26-023-30-71	-	26-022-30-71

Instruments **LINOS**
Screw Osteosynthesis Ø 1.2 mm

Standard instruments for the add-on module Ø 1.2 mm



26-975-42-07
Drill guide
Ø 1.2 mm



26-975-43-07
Drill sleeve
Ø 1.2 mm



26-975-44-07
26-975-44-71
Core hole drill
Ø 1.0 mm



STERILE 



26-975-28-07
Depth gauge
Ø 1.2/1.5 mm
One-handed design









26-975-33-07
T5 screwdriver
Short, rotatable
15 cm





Explanation of icons

-  Screw diameter 1.2 mm
-  Screw diameter 1.5 mm
-  Steel
-  Silicone
-  T-Drive
-  Dental attachment
-  Packaging unit

STERILE | R Sterile packaged instruments

Standard instruments for the add-on module Ø 1.2 mm



1/2

26-975-38-07
T5 screwdriver
Short, non-rotatable
15 cm

- 
- 
- 
- 
- 



1/2

26-975-45-71
Gliding hole drill
Ø 1.2 mm

- 
- 
- 
- 

STERILE | R

Instruments **LINOS** Plate and Screw Osteosynthesis

Standard instruments Ø 1.5 mm



26-975-75-07
Drill guide
Ø 1.5 mm



26-153-11-07
26-153-11-71
Core hole drill
Ø 1.1 mm



STERILE IR



26-975-77-07
Drill sleeve
compression
Ø 1.5 mm



26-153-15-07
26-153-15-71
Gliding hole drill
Ø 1.5 mm



STERILE IR









26-975-76-07
Drill sleeve
gliding hole
Ø 1.5 mm





Explanation of icons

-  Screw diameter 1.5 mm
-  Screw diameter 2.0 mm
-  Steel
-  Silicone
-  T-Drive
-  Packaging unit

STERILE IR Sterile packaged instruments

Standard instruments Ø 2.0 mm



1/2

26-975-80-07
Drill guide
Ø 2.0 mm



1/2

26-153-16-07
26-153-16-71
Core hole drill
Ø 1.5 mm

STERILE IR



1/2

26-975-82-07
Drill sleeve
compression
Ø 2.0 mm



1/2

26-153-20-07
26-153-20-71
Gliding hole drill
Ø 2.0 mm

STERILE IR



1/2

26-975-81-07
Drill sleeve
gliding hole
Ø 2.0 mm

Instruments **LINOS** Plate and Screw Osteosynthesis

Standard instruments Ø 2.3 mm



26-975-85-07
Drill guide
Ø 2.3 mm



26-153-18-07
26-153-18-71
Core hole drill
Ø 1.8 mm



STERILE IR



26-975-87-07
Drill sleeve
compression
Ø 2.3 mm



26-153-23-07
26-153-23-71
Gliding hole drill
Ø 2.3 mm



STERILE IR











26-975-86-07
Drill sleeve
gliding hole
Ø 2.3 mm





Explanation of icons

-  Screw diameter 1.0 mm
-  Screw diameter 1.5 mm
-  Screw diameter 2.0 mm
-  Screw diameter 2.3 mm
-  Steel
-  Silicone
-  Dental attachment
-  AO attachment
-  Packaging unit

STERILE R Sterile packaged instruments





Optional Instruments



Ø Screw

Core hole drill
(1 color ring)

Glidig hole drill
(2 color rings)

1.2 mm 	Ø 1.0 mm 26-158-10-71	Ø 1.2 mm 26-158-12-71
1.5 mm 	Ø 1.1 mm 26-158-11-71	Ø 1.5 mm 26-158-15-71
2.0 mm 	Ø 1.5 mm 26-158-16-71	Ø 2.0 mm 26-158-20-71
2.3 mm 	Ø 1.8 mm 26-158-18-71	Ø 2.3 mm 26-158-23-71



1/2

26-975-25-07
Depth gauge
Ø 1.5/2.0/2.3 mm
One-handed design



Instruments **LINOS** Plate and Screw Osteosynthesis

Standard instruments Ø 1.5 mm, 2.0 mm and 2.3 mm



1/2

26-975-28-07
Depth gauge
Ø 1.2/1.5 mm
One-handed design



1/2

26-975-30-07
Depth gauge
Ø 2.0/2.3 mm
One-handed design



1/2

26-975-36-07
Screwdriver
T6
Short, rotatable



1/2

26-975-39-07
Screwdriver
T6
Short, non-rotatable



1/2

26-975-03-07
Plate holding
and positioning
instrument



1/2









26-975-06-07
Reduction forceps*
Pointed-pointed
14 cm



* European patent pending



Explanation of icons

-  Screw diameter 1.2 mm
-  Screw diameter 1.5 mm
-  Screw diameter 2.0 mm
-  Screw diameter 2.3 mm
-  Steel
-  Silicone
-  T-Drive
-  Packaging unit



23-721-09-07
Reduction forceps
acc. Backhaus
9 cm

St 1



26-975-04-07
Plate holding forceps

St 1



26-975-05-07
Bending forceps

St 1



26-975-89-07
K-wire
dispenser
Ø 0.9 mm

St 1



26-975-90-07
K-wires
Ø 0.9 mm

St 10
units



26-975-02-04
Screw measuring
clip
Length and diameter

Storage System **LINOS** non-sterile packed Implants



Implant storage

When the LINOS implant storage container was being developed, the focus was not only on optimizing the reprocessing capability but also on practice-oriented implementation of batch traceability.

To meet the requirements of any particular user, two sizes of storage baskets are available, which can be configured with a various number of screw and plate modules.

For transparent organization and easy identification all the module fronts have color-coded labeling clips that clearly indicate the contents.

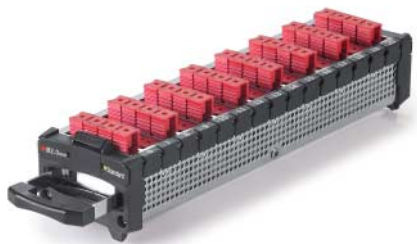

Every **screw module** can accommodate a total of 60 screws in lengths ranging from 6 to 20 mm, all stored in single clips. The clips, which are labeled with screw length and diameter, article number, and batch number, permit not only easy recording of all the relevant implant data but also seamless patient-related documentation.



In the **plate module** the plates are clearly arranged and kept separate from each other. Each plate compartment is marked at the side with a labeling clip that bears the article number, the profile, and a picture of the plate. As a result, all the necessary information is provided for application-oriented access and intuitive refilling. The matt inner surface of the module allows comfortable, dazzle-free work under the surgical light.

The stackable modules, which are available in coordinated sizes, can also be used individually, without a storage basket. Consequently, it is possible to customize set design in a simple and practical manner.



Instrument storage

The instruments are stored in a separate basket, which is described on pages 62 and 63.

Storage System **LINOS** non-sterile packed Implants

Set 1

55-911-15-04 Implant storage COMPLETE, consisting of:

55-911-21-04	Storage cage, big		
55-911-31-04	Plate module 2/3, configured for plates in plate profile 0.8 mm*		
55-911-32-04	Plate module 2/3, configured for plates in plate profile 1.2 mm**		
55-911-22-04	Screw module, standard screws Ø 1.5 mm	55-911-25-04	Screw module, locking screws Ø 1.5 mm
55-911-23-04	Screw module, standard screws Ø 2.0 mm	55-911-26-04	Screw module, locking screws Ø 2.0 mm
55-911-24-04	Screw module, standard screws Ø 2.3 mm	55-911-27-04	Screw module, locking screws Ø 2.3 mm



55-911-21-04
Storage cage, big



55-911-31-04
Plate module, plate profile 0.8 mm



55-911-32-04
Plate module, plate profile 1.2 mm



55-911-22-04
Screw module, standard screws Ø 1.5 mm



55-911-23-04
Screw module, standard screws Ø 2.0 mm



55-911-24-04
Screw module, standard screws Ø 2.3 mm



55-911-25-04
Screw module, locking screws Ø 1.5 mm



55-911-26-04
Screw module, locking screws Ø 2.0 mm



55-911-27-04
Screw module, locking screws Ø 2.3 mm

Note: Every screw module can accommodate a total of 60 screws in lengths ranging from 6 to 20 mm, all stored in single clips; 4 standard screws respectively 4 locking screws per length.



	* Plate module 55-911-31-04 can accommodate all plates with profile 0.8 mm	
26-108-12-09	Straight plate 4-hole, length 19.5 mm	□□□□
26-108-13-09	Straight plate 5-hole, length 26.5 mm	□□□□□
26-108-14-09	Straight plate 6-hole, length 31.5 mm	□□□□□□
26-108-15-09	Grid plate 2/2-hole, length 10.5 mm	■ ■
26-108-16-09	Grid plate 2/3-hole, length 15.5 mm	■ ■ ■
26-108-17-09	Grid plate 2/4-hole, length 20.5 mm	■ ■ ■ ■
26-108-18-09	Grid plate 2/5-hole, length 25.5 mm	■ ■ ■ ■ ■
26-108-19-09	Grid plate 2/6-hole, length 30.5 mm	■ ■ ■ ■ ■ ■
26-108-20-09	Z-plate 9-hole, length 24.5 mm	⌈⌋⌈⌋⌈⌋⌈⌋⌈⌋⌈⌋⌈⌋⌈⌋
26-108-21-09	Z-plate 13-hole, length 34.5 mm	⌈⌋⌈⌋⌈⌋⌈⌋⌈⌋⌈⌋⌈⌋⌈⌋⌈⌋⌈⌋⌈⌋⌈⌋⌈⌋
26-108-22-09	Correction plate 3/3-hole, length 26 mm	⌈⌋⌈⌋⌈⌋
26-108-06-09	T-plate 2/3-hole, length 19.5 mm	⌈⌋⌈⌋⌈⌋
26-108-07-09	T-plate 2/4-hole, length 26.5 mm	⌈⌋⌈⌋⌈⌋⌈⌋
26-108-08-09	T-plate 2/5-hole, length 31.5 mm	⌈⌋⌈⌋⌈⌋⌈⌋⌈⌋
26-108-09-09	T-plate 3/3-hole, length 19.5 mm	⌈⌋⌈⌋⌈⌋
26-108-10-09	T-plate 3/4-hole, length 26.5 mm	⌈⌋⌈⌋⌈⌋⌈⌋
26-108-11-09	T-plate 3/5-hole, length 31.5 mm	⌈⌋⌈⌋⌈⌋⌈⌋⌈⌋
26-108-03-09	Y-plate 2/3-hole, length 18 mm	⌈⌋⌈⌋⌈⌋
26-108-04-09	Y-plate 2/4-hole, length 25 mm	⌈⌋⌈⌋⌈⌋⌈⌋
26-108-05-09	Y-plate 2/5-hole, length 30 mm	⌈⌋⌈⌋⌈⌋⌈⌋⌈⌋
26-108-01-09	L-plate 6-hole, right, length 26.5 mm	⌈⌋⌈⌋⌈⌋⌈⌋⌈⌋⌈⌋
26-108-02-09	L-plate 6-hole, left, length 26.5 mm	⌈⌋⌈⌋⌈⌋⌈⌋⌈⌋⌈⌋

	** Plate module 55-911-32-04 can accommodate the following plates with profile 1.2 mm	
26-112-12-09	Straight plate 4-hole, length 24.5 mm	□□□□
26-112-13-09	Straight plate 5-hole, length 32 mm	□□□□□
26-112-14-09	Straight plate 6-hole, length 38.5 mm	□□□□□□
26-112-27-09	Straight plate 7-hole, length 45 mm	□□□□□□□
26-112-15-09	Grid plate 2/2-hole, length 11.5 mm	■ ■
26-112-16-09	Grid plate 2/3-hole, length 18 mm	■ ■ ■
26-112-17-09	Grid plate 2/4-hole, length 24.5 mm	■ ■ ■ ■
26-112-18-09	Grid plate 2/5-hole, length 31 mm	■ ■ ■ ■ ■
26-112-19-09	Grid plate 2/6-hole, length 37.5 mm	■ ■ ■ ■ ■ ■
26-112-20-09	Z-plate 9-hole, length 31 mm	⌈⌋⌈⌋⌈⌋⌈⌋⌈⌋⌈⌋⌈⌋⌈⌋
26-112-21-09	Z-plate 13-hole, length 44 mm	⌈⌋⌈⌋⌈⌋⌈⌋⌈⌋⌈⌋⌈⌋⌈⌋⌈⌋⌈⌋⌈⌋⌈⌋⌈⌋
26-112-01-09	L-plate 7-hole, right, length 38.5 mm	⌈⌋⌈⌋⌈⌋⌈⌋⌈⌋⌈⌋⌈⌋
26-112-02-09	L-plate 7-hole, left, length 38.5 mm	⌈⌋⌈⌋⌈⌋⌈⌋⌈⌋⌈⌋⌈⌋
26-112-22-09	Correction plate 3/3-hole, length 31 mm	⌈⌋⌈⌋⌈⌋
26-112-06-09	T-plate 2/3-hole, length 24.5 mm	⌈⌋⌈⌋⌈⌋
26-112-07-09	T-plate 2/4-hole, length 32 mm	⌈⌋⌈⌋⌈⌋⌈⌋
26-112-08-09	T-plate 2/5-hole, length 38.5 mm	⌈⌋⌈⌋⌈⌋⌈⌋⌈⌋
26-112-25-09	T-plate 2/6-hole, length 45 mm	⌈⌋⌈⌋⌈⌋⌈⌋⌈⌋⌈⌋
26-112-09-09	T-plate 3/3-hole, length 24.5 mm	⌈⌋⌈⌋⌈⌋
26-112-10-09	T-plate 3/4-hole, length 32 mm	⌈⌋⌈⌋⌈⌋⌈⌋
26-112-11-09	T-plate 3/5-hole, length 38.5 mm	⌈⌋⌈⌋⌈⌋⌈⌋⌈⌋
26-112-26-09	T-plate 3/6-hole, length 45 mm	⌈⌋⌈⌋⌈⌋⌈⌋⌈⌋⌈⌋
26-112-03-09	Y-plate 2/3-hole, length 22.6 mm	⌈⌋⌈⌋⌈⌋
26-112-04-09	Y-plate 2/4-hole, length 30.1 mm	⌈⌋⌈⌋⌈⌋⌈⌋
26-112-05-09	Y-plate 2/5-hole, length 36.5 mm	⌈⌋⌈⌋⌈⌋⌈⌋⌈⌋
26-112-24-09	Y-plate 2/6-hole, length 43 mm	⌈⌋⌈⌋⌈⌋⌈⌋⌈⌋⌈⌋

Storage System **LINOS** non-sterile packed Implants

Individual Components

Storage cages

55-911-20-04	Storage cage, small, for 2 plate and 4 screw modules
55-911-21-04	Storage cage, big, for 2 plate and 6 screw modules



55-911-20-04
Storage cage, small



55-911-21-04
Storage cage, big

Plate modules

55-911-31-04	Plate module 2/3, configured for plates in plate profile 0.8 mm
55-911-32-04	Plate module 2/3, configured for plates in plate profile 1.2 mm



55-911-31-04
Plate module, plate profile 0.8 mm



55-911-32-04
Plate module, plate profile 1.2 mm



Screw modules

55-911-22-04	Screw module, standard screws Ø 1.5 mm	55-911-25-04	Screw module, locking screws Ø 1.5 mm
55-911-23-04	Screw module, standard screws Ø 2.0 mm	55-911-26-04	Screw module, locking screws Ø 2.0 mm
55-911-24-04	Screw module, standard screws Ø 2.3 mm	55-911-27-04	Screw module, locking screws Ø 2.3 mm



55-911-22-04
Screw module, standard screws Ø 1.5 mm



55-911-23-04
Screw module, standard screws Ø 2.0 mm



55-911-24-04
Screw module, standard screws Ø 2.3 mm



55-911-25-04
Screw module, locking screws Ø 1.5 mm



55-911-26-04
Screw module, locking screws Ø 2.0 mm



55-911-27-04
Screw module, locking screws Ø 2.3 mm

Screw modules combination*

55-911-28-04	Screw module, standard- and locking screws Ø 1.5 mm
55-911-29-04	Screw module, standard- and locking screws Ø 2.0 mm
55-911-30-04	Screw module, standard- and locking screws Ø 2.3 mm



55-911-28-04
Screw module, standard/locking screws Ø 1.5 mm



55-911-29-04
Screw module, standard/locking screws Ø 2.0 mm



55-911-30-04
Screw module, standard/locking screws Ø 2.3 mm

* **Note:** Every screw module can accommodate a total of 60 screws in lengths ranging from 6 to 20 mm, all stored in single clips; 2 standard **and** 2 locking screws per length.

Storage System **LINOS** Instruments

The instrument storage boasts easy and well-thought-out ergonomic handling, with the instruments arranged according to the sequence of use during the surgical procedure. In addition it has been optimized for superior reprocessing results to satisfy the requirements of all those involved.

The proven concept – based on a combination of stainless steel in honeycomb design and high-performance plastic - provides not only great stability at a low weight, but ensures an excellent rinsing performance as well.

All the instruments required for the surgical procedure can be stored side by side in the storage cage. The optional module used for 1.2 mm screw osteosynthesis can also be accommodated.



55-910-61-04	Instrument storage set complete, consisting of:	Optional:	
55-910-62-04	Storage cage	55-910-64-04	Instrument tray 1.2 mm
55-910-63-04	Instrument tray		
55-910-59-04	Lid		



55-910-62-04
Storage cage

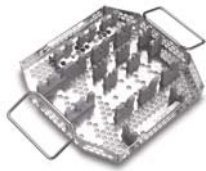

55-910-63-04
Instrument tray



55-910-59-04
Lid



55-910-64-04
Instrument tray 1.2 mm

Storage System **LINOS** sterile packed Implants

Apart from the option of conventional storage, the entire LINOS system is also available with sterile packed implants.

The storage concept for **LINOS STERILE** consists of various components:

The sterile goods trolley is ideal for easy handling and supply of sterile implants, both in the operating room and in terms of logistics. The labeled baskets and storage compartments coordinated with LINOS ensure structured stockkeeping, provide a good overview and allow easy access to the individual items.

In the open-design instrument storage tray all the instruments required for an operation can be stored individually. The optional instrument tray for Ø 1.2-mm screw osteosynthesis can also be accommodated.

For storing LINOS templates a special template storage tray is available, the design of which is adapted to the instrument storage. In the two template trays the 0.8-mm and 1.2-mm templates can be stored separately from each other. Special labeling clips with a pictogram and article number of the LINOS plate corresponding to the template ensure the right choice of sterile implant.



55-910-61-04	Instrument storage set complete, consisting of:	Optional:
55-910-62-04	Storage cage	55-910-64-04 Instrument tray 1.2 mm
55-910-63-04	Instrument tray	
55-910-59-04	Lid	



55-910-62-04
Storage cage



55-910-63-04
Instrument tray



55-910-59-04
Lid



55-910-64-04
Instrument tray 1.2 mm

55-910-65-04	Template storage set complete,, consisting of:
55-910-66-04	Storage cage
55-910-77-04	Template tray 0.8 mm, with lid
55-910-78-04	Template tray 1.2 mm, with lid
55-910-59-04	Lid



55-910-66-04
Storage cage



55-910-77-04
Template tray 0.8 mm,
with Lid



55-910-78-04
Template tray 1.2 mm,
with lid



55-910-59-04
Lid



55-900-50-04
Sterile goods trolley, preconfigured,
incl. 7 cages, 66 x 150 x 49 cm (W x H x D)

55-900-50-04	Sterile goods trolley, preconfigured
---------------------	---------------------------------------------

Hand Surgery

A field where we can offer you much more than just standard treatment solutions for, say, distal radius fractures. Many of our products are intended to help you to achieve outstanding results in difficult, non-everyday situations as well. Products such as our Ulna Head Prosthesis (UHP) or the Flower Plate for mediocarpal partial arthrodesis are excellent examples.

Our objective is to simplify hand surgery interventions via intelligent system solutions, helping you to achieve the best possible results in the interest of the patient. Working in close cooperation with well-known authors and their teams, we have translated new ideas into innovative products that are consistently being developed further in an ongoing process. The result is a wide range of high-quality systems that impress with their clever design along with easy and safe handling.

Furthermore we have never lost sight on the economic perspective and service needs of our customers.

We consider ourselves as a true partner – to be relied upon for routine tasks and special challenges alike.

LINOS
for hand fracture treatment

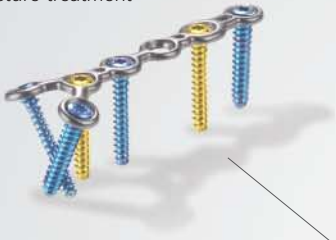

CapFlex PIP
for endoprosthetic treatment
of the PIP joints



HBS2
for the treatment of
fractures and non-unions
in small bones



GENOS
for internal distraction
of metacarpal bones



CANOS
cannulated screws for
the treatment of small
bone fractures



Flower Plate
for mediocarpal partial
arthrodesis



IXOS®
for the treatment of distal
radius fractures



UHP
for treating disorders of the
distal radioulnar joint



RECOS®
for ulnar shortening and
radius reconstruction
osteotomies



KLS Martin Group

KLS Martin France SARL
68200 Mulhouse · France
Tel. +33 3 89 51 31 50
france@klsmartin.com

KLS Martin UK Ltd.
Reading RG1 3EU · United Kingdom
Tel. +44 1189 000 570
uk@klsmartin.com

KLS Martin do Brasil Ltda.
CEP 04.531-011 São Paulo · Brazil
Tel.: +55 11 3554 2299
brazil@klsmartin.com

Gebrüder Martin GmbH & Co. KG
Representative Office
121471 Moscow · Russia
Tel. +7 499 792-76-19
russia@klsmartin.com

Martin Italia S.r.l.
20864 Agrate Brianza (MB) · Italy
Tel. +39 039 605 67 31
italia@klsmartin.com

Nippon Martin K.K.
Tokyo 113-0024 · Japan
Tel. +81 3 3814 1431
nippon@klsmartin.com

KLS Martin Australia Pty Limited
Artarmon NSW 2064 · Australia
Tel.: +61 2 9439 5316
australia@klsmartin.com

Gebrüder Martin GmbH & Co. KG
Representative Office
201203 Shanghai · China
Tel. +86 21 5820 6251
china@klsmartin.com

Martin Nederland/Marned B.V.
1271 AG Huizen · The Netherlands
Tel. +31 35 523 45 38
nederland@klsmartin.com

KLS Martin L.P.
Jacksonville, FL 32246 · USA
Tel. +1 904 641 77 46
usa@klsmartin.com

KLS Martin SE Asia Sdn. Bhd.
14100 Simpang Ampat, Penang · Malaysia
Tel.: +604 505 7838
malaysia@klsmartin.com

Gebrüder Martin GmbH & Co. KG
Representative Office
Dubai · United Arab Emirates
Tel. +971 4 454 16 55
middleeast@klsmartin.com

Gebrüder Martin GmbH & Co. KG
A company of the KLS Martin Group
KLS Martin Platz 1 · 78532 Tuttlingen · Germany
Postfach 60 · 78501 Tuttlingen · Germany
Tel. +49 7461 706-0 · Fax +49 7461 706-193
info@klsmartin.com · www.klsmartin.com

